

Technical Specification	PSI5	
	Peripheral Sensor Interface – Base Standard	V2.3

Peripheral Sensor Interface for Automotive Applications

All rights including industrial property rights and all rights of disposal such as copying and passing to third parties reserved.

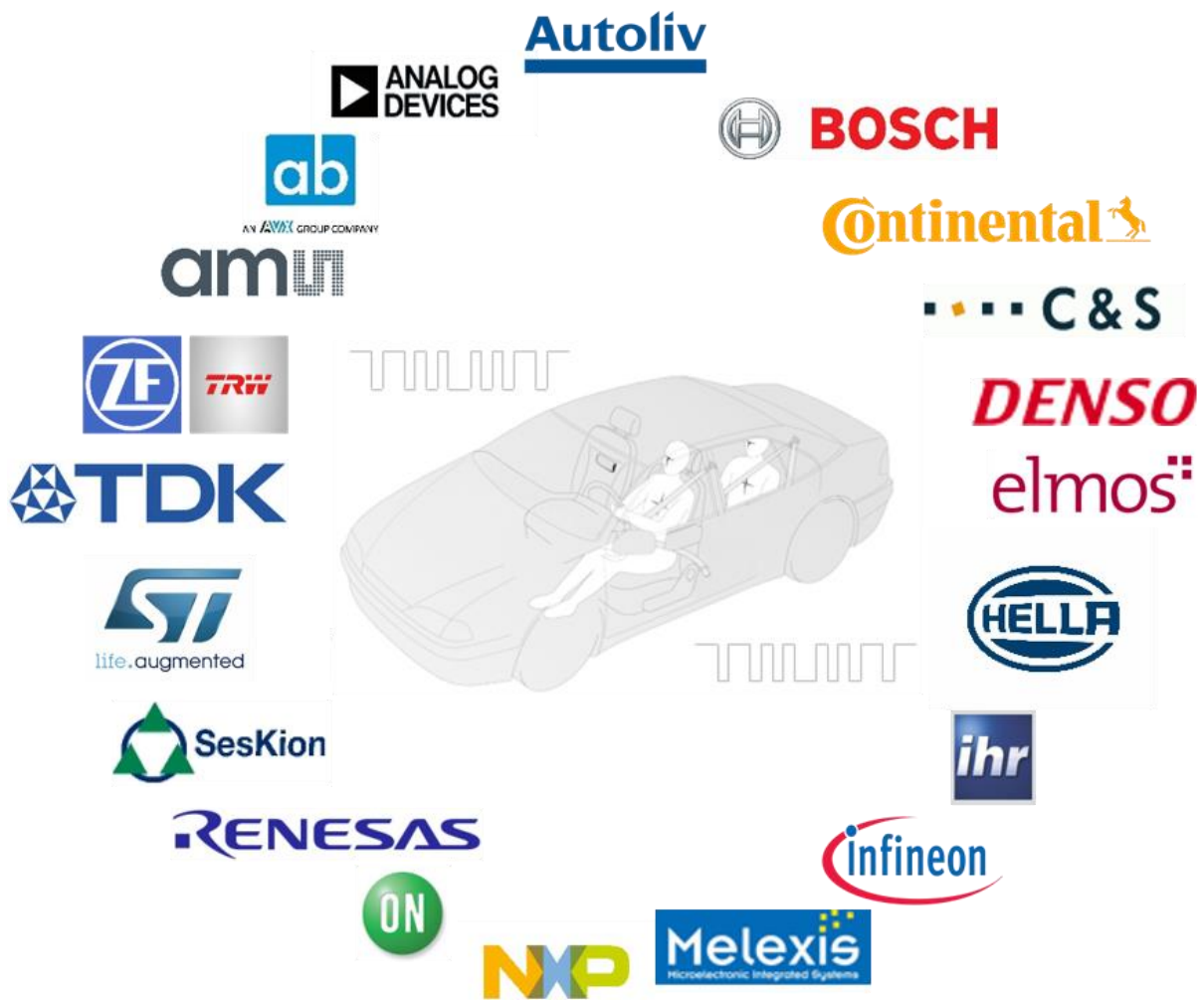

Technical Specification	PSI5	I
	Peripheral Sensor Interface – Base Standard	V2.3

Contents

1	Introduction	1
1.1	Description.....	1
1.2	PSI5 Main Features	1
1.3	Scope	2
1.4	Legal Information	2
1.4.1	Disclaimer	2
1.4.2	Indemnification.....	2
2	Definition of Terms	4
2.1	Glossary	4
2.2	Symbols / Parameters.....	5
2.2.1	General Parameters	5
2.2.2	Communication Parameters	6
2.2.3	Supply Line and Bus Parameters.....	7
2.3	Acronyms, Abbreviations.....	8
3	Data Link Layer	9
3.1	Sensor to ECU Communication.....	9
3.1.1	Data Frames	9
3.1.2	Data Frame Format.....	9
3.1.3	Scaling of Sensor Output (for data words longer than 10 bit).....	10
3.1.4	Serial Channel.....	11
3.2	ECU to Sensor Communication.....	12
3.2.1	Data Frames	12
3.2.2	Frame Formats - Tooth Gap method.....	12
3.2.3	Frame Formats – Pulse Width method.....	13
3.2.4	Mapping of Data frames for Pulse Width method	14
3.3	Error Detection.....	15
3.3.1	Parity Bit	15
3.3.2	3 bit CRC	15
3.3.3	6 bit CRC	16
4	Physical Layer	18
4.1	General.....	18
4.2	Supply Line Model.....	18
4.3	Single Sensor, Point to Point Topologies	19
4.3.1	Single Sensor, Point to Point Asynchronous Topologies (PSI5-A).....	19
4.3.2	Parameter Specification for Single Sensor Configuration	19
4.4	Multi Sensor, Bus Topologies.....	19

Technical Specification	PSI5	II
	Peripheral Sensor Interface – Base Standard	V2.3

4.4.1	Synchronous Parallel Bus Mode (PSI5-P).....	19
4.4.2	Synchronous Universal Bus Mode (PSI5-U).....	20
4.4.3	Synchronous Daisy Chain Bus Mode (PSI5-D)	21
4.4.4	Parameter Specification for Bus Topologies.....	22
4.5	Sensor to ECU Communication.....	23
4.6	ECU to Sensor Communication.....	24
4.6.1	Tooth Gap method	24
4.6.2	Pulse Width method	24
4.7	General Parameters.....	25
4.7.1	Supply and Communication Parameters Definitions.....	25
4.7.2	Absolute Maximum Ratings	28
4.7.3	Configuration Modes & Options	28
4.8	Dynamic Bus Behavior	30
4.8.1	Test Network Parameters	30
4.8.1.1	Sensor Damping Behavior	30
4.8.1.2	Sensor Testing	31
4.8.1.3	ECU Testing.....	32
4.8.2	Requirements for Dynamic Sensor Testing.....	32
4.8.3	Requirements for Dynamic ECU Testing.....	33
4.9	Synchronization Signal.....	34
4.10	Timing Definitions for Synchronous Operation Modes.....	38
4.10.1	Generic Time Slot Calculation	39
4.11	Sensor Power-on Characteristics	41
4.11.1	Sensor Bus Configuration.....	41
4.11.2	Extended Settling Time for Single Sensor Configuration	42
4.12	Undervoltage Reset and Microcut Rejection	43
5	Application Layer	45
5.1	Data Range.....	45
5.1.1	Scaling of Sensor Output.....	46
5.2	Sensor Initialization / Identification.....	46
5.2.1	Frame Format - Data Range Initialization.....	47
5.2.2	Data Content - Data Range Initialization	48
5.2.3	Meta Information	49
5.2.4	Vendor ID.....	50
5.3	Bidirectional Communication	51
5.3.1	Sensor Addresses	51
5.3.2	Function Codes and Responses for Bidirectional Communication – Frame 1 to 3	52
5.3.3	Returned Error Codes – Sensor Response for Frame 1-3.....	52
6	System Setup & Operation Modes	54

Technical Specification	PSI5	III
	Peripheral Sensor Interface – Base Standard	V2.3

6.1	System Setup.....	54
6.2	PSI5 Operation Modes	54
6.3	Asynchronous Operation (PSI5-A).....	56
6.4	Synchronous Operation.....	56
	6.4.1 Timing of Synchronous Operation Modes	57
	6.4.2 Bus Operation Principle.....	57
	6.4.2.1 Preferred Daisy-Chain Mode: Parallel Initialization Phase)	58
	6.4.3 Sensor Cluster / Multichannel	59
7	Interoperability Requirements	61
8	Document History & Modifications	62

All rights including industrial property rights and all rights of disposal such as copying and passing to third parties reserved.

Technical Specification	PSI5	IV
	Peripheral Sensor Interface – Base Standard	V2.3

List of Figures

Figure 1: Example of a data frame with 10 data bits (D0-D9), 2 start bits (S1,S2) and one parity bit (P).	9
Figure 2: Different parts of the PSI5 data frame	10
Figure 3: Scaling of data range	11
Figure 4: Serial data frame generated by the two messaging bits of the sensor data frame (messaging channel)	12
Figure 5: ECU to sensor communication with Tooth Gap method	13
Figure 6: Data frames 1-3 for ECU to sensor communication with Tooth Gap method	13
Figure 7: ECU to sensor communication with Pulse Width method	14
Figure 8: Data frame 4 for ECU to sensor communication with Pulse Width method	14
Figure 9: Mapping of frames 1-3 into frame 4	15
Figure 10: Bit Data word example with 3-Bit CRC.....	16
Figure 11: Reading order for checksum generation in sensor to ECU serial communication.....	17
Figure 12: Example for checksum generation, 12-Bit data field, 8-Bit message ID and 6-Bit CRC for sensor to ECU serial communication channel	17
Figure 13: Supply line model for PSI5	18
Figure 14: Single sensor configuration (simplified diagram)	19
Figure 15: Synchronous parallel bus mode (simplified schematic)	20
Figure 16: Example for a pass-through configuration (simplified schematic)	21
Figure 17: Example for a splice configuration (simplified schematic)	21
Figure 18: Synchronous daisy chain bus (simplified schematic).....	22
Figure 19: Bit encoding and data frame timing for sensor to ECU communication.....	23
Figure 20: Bit encoding according to the Tooth Gap method.....	24
Figure 21: Bit encoding via Pulse Width method.....	25
Figure 22: System current and voltage definitions.....	26
Figure 23: Reference circuit for sensor damping behavior	31
Figure 24: Reference circuit for sensor testing.....	32
Figure 25: Reference circuit for ECU testing.....	32
Figure 26: Dynamic behavior of supply / communication current.....	33
Figure 27: Shape and timing of synchronization signal at ECU	35
Figure 28: Synchronization signal detection in the sensor.....	37
Figure 29: Timing of synchronous operation	39
Figure 30: Current consumption during startup for sensor bus configuration	41
Figure 31: Current consumption during start up for certain single sensor configurations.....	42
Figure 32: Undervoltage reset behavior.....	43
Figure 33: Mapping of status and initialization data into a data word	46
Figure 34: Sensor initialization sequence for Data Range Initialization	47
Figure 35: Block ID and data nibbles	48
Figure 36: Startup sequence	48

Technical Specification	PSI5	V
	Peripheral Sensor Interface – Base Standard	V2.3

Figure 37: Connection of peripheral sensors to an ECU (Example)..... 54

Figure 38: Denomination of PSI5 operation modes..... 55

Figure 39: PSI5-A asynchronous point-to-point connection..... 56

Figure 40: Fixed time triggered synchronous operation..... 57

Figure 41: Variable time triggered synchronous operation 57

Figure 42: Basic PSI5 bus topology..... 57

Figure 43: Daisy chain bus topology..... 58

Figure 44: Daisy chain bus implementation (example with 4 time slots) 59

Figure 45: Implementation example sensor cluster 60

All rights including industrial property rights and all rights of disposal such as copying and passing to third parties reserved.

Technical Specification	PSI5 Peripheral Sensor Interface – Base Standard	VI
		V2.3

List of Tables

Table 1: Glossary.....	4
Table 2: Symbol definitions – ECU side.....	5
Table 3: Symbol definitions – Sensor side	6
Table 4: Symbol definitions – ECU to sensor communication.....	6
Table 5: Symbol definitions – Sensor to ECU communication.....	7
Table 6: Symbol definitions – Supply Line	7
Table 7: Symbol definitions – Bus	8
Table 8: Acronyms, Abbreviations	8
Table 9: Different parts of the payload.....	10
Table 10: Parameter specification for supply line model	18
Table 11: Parameter specification for single sensor configuration	19
Table 12: Parameter specification for bus topologies.....	22
Table 13: Parameter specification of sensor to ECU communication (related to the sensor).....	23
Table 14: System parameter specification	26
Table 15: Parameter specification of absolute maximum ratings.....	28
Table 16: Parameter compilation for Common Mode and Low Power Mode operation	29
Table 17: Reference network for sensor testing.....	31
Table 18: Reference network for ECU testing.....	32
Table 19: Parameter specification for sensor reference test.....	33
Table 20: Parameter specification for ECU reference test.....	34
Table 21: Parameter specification of synchronization signal	35
Table 22: Parameter specification of synchronization signal detection at the sensor	37
Table 23: Settling time specification for sensor bus configuration.....	41
Table 24: Extended settling time specification for single sensor configuration	42
Table 25: Parameter specification for undervoltage reset and microcut rejection.....	43
Table 26: Data range (10 Bit)	45
Table 27: Mandatory definitions.....	48
Table 28: Initialization data content	49
Table 29: Meta Header	50
Table 30: Vendor IDs.....	50
Table 31: Combination of bidirectional communication options	51
Table 32: Sensor addresses.....	51
Table 33: Function codes and responses for bidirectional communication – Frame 1 to 3.....	52
Table 34: Returned error codes – Sensor response for Frame 1-3.....	52
Table 35: PSI5 operation modes	55

Technical Specification	PSI5	1 / 65
	Peripheral Sensor Interface – Base Standard	V2.3

1 Introduction

1.1 Description

1 The Peripheral Sensor Interface (PSI5) is an interface for automotive sensor applications. PSI5 is an open
2 standard based on existing sensor interfaces for peripheral airbag sensors, already proven in millions of airbag
3 systems. The technical characteristics, the low implementation overhead as well as the attractive cost make
4 the PSI5 also suitable for many other automotive sensor applications.

5 Development goal of the PSI5 is a flexible, reliable communication standard for automotive sensor applications
6 that can be used and implemented free of charge.

7 The PSI5 development and the publication of the PSI5 Technical Specification V2.3, comprised by a Base
8 Standard (this document) and three application specific Substandards (“Airbag”, “Chassis and Safety” and
9 “Powertrain”), are responsibly managed by the “PSI5 Steering Committee”, formed by the companies Autoliv,
10 Bosch, and Continental.

11 This Base Standard version is a joint development of the companies AB ELEKTRONIK, AMS, Analog Devices,
12 Autoliv, Bosch, Continental, CS Group, Denso, ELMOS, Hella, IHR, Infineon, Melexis, NXP,
13 ON Semiconductor, Renesas, Seskion, ST, TDK and ZF TRW.

1.2 PSI5 Main Features

14 Main features of the PSI5 are high speed and high reliability data transfer at lowest possible implementation
15 overhead and cost. PSI5 covers the requirements of the low-end segment of digital automotive interfaces and
16 offers a universal and flexible solution for multiple sensor applications. It is characterized by

- 17 • Two-wire current interface
- 18 • Manchester coded digital data transmission
- 19 • High data transmission speed of 125kbps or optional 189kbps
- 20 • High EMC robustness and low emission
- 21 • Wide range of sensor supply current
- 22 • Variable data word length (10 to 28 bit with one bit granularity)
- 23 • Asynchronous or synchronous operation and different bus modes
- 24 • Bidirectional communication

25 PSI5 Technical Specification V2.3 provides a new structure in terms of Physical, Data Link and Application
26 Layer in order to ease the application of the PSI5 Interface. Due to backward compatibility established
27 parameters according to PSI5 Technical Specification V1.3 are still valid; the alternative implementations are
28 mainly optional and specifically indicated.

29 Though, general interface parameters are given within this Base Standard, application specific frameworks
30 and conditions are given in the effective Substandards “Airbag”, “Chassis and Safety” and “Powertrain”.

Technical Specification	PSI5 Peripheral Sensor Interface – Base Standard	2 / 65
		V2.3

1.3 Scope

31 This document describes the interface according to the ISO/OSI reference model and contains the
32 corresponding parameter specifications. PSI5 standardizes the low level communication between peripheral
33 sensors and electronic control units.

1.4 Legal Information

34 The specification may be reproduced or copied, subject to acceptance of the contents of this document.
35 No part of this specification may be modified or translated in any form or by any means without prior written
36 permission of Autoliv, Bosch, and Continental. With their permission Autoliv, Bosch, and Continental assume
37 no liability for the modifications or translations made by third parties.
38 In case Autoliv, Bosch, and Continental permit any of the aforementioned modifications or translations Autoliv,
39 Bosch, and Continental shall be entitled to use such modifications or translations free of charge for future
40 versions of the PSI5 protocol and make such future versions available to third parties under the same terms
41 and conditions as for the PSI5 protocol.

1.4.1 Disclaimer

42 The specification and all enclosed documents are provided to you "AS IS". You assume total responsibility and
43 risk for your use of them including the risk of any defects or inaccuracies therein.
44 Autoliv, Bosch, Continental and the other members of the PSI5 Consortium do not make, and expressly
45 disclaim, any express or implied warranties of any kind whatsoever, including, without limitation, implied
46 warranties of merchantability of fitness for a particular purpose, warranties or title or non-infringement.
47 The PSI5-consortium shall not be liable for
48 (a) any incidental, consequential, or indirect damages (including, without limitation, damages for loss of
49 profits, business interruption, loss of programs or information, and the like) arising out of the use of
50 or inability to use the specification or enclosed documents,
51 (b) any claims attributed to errors, omissions, or other inaccuracies in the specification or enclosed
52 documents.

53 As far as personal injuries are caused due to the specification or any of the enclosed documents and to the
54 extent the mandatory laws of the law applicable restrict the limitation of liability in such cases or in other
55 circumstances as for example liability due to willful intent, fraudulently concealed defects or breach of cardinal
56 obligations, the mandatory law applicable shall remain unimpaired.

1.4.2 Indemnification

57 You shall indemnify and hold harmless Autoliv, Bosch, Continental and all members of the PSI5 consortium,
58 their affiliates and authorized representatives against any claims, suits or proceedings asserted or commenced
59 by any third party and arising out of, or relating to, you using the specification or enclosed documents. This
60 obligation shall include indemnification against all damages, losses, costs and expenses (including attorneys'
61 fees) incurred by the consortium, their affiliates and authorized representatives as a result of any such claims,

Technical Specification	PSI5 Peripheral Sensor Interface – Base Standard	3 / 65
		V2.3

- 62 suits or proceedings, including any costs or expenses incurred in defending against any such claims, suits, or
- 63 proceedings.
- 64 By making use of the PSI5 protocol you declare your approval with the above standing terms and conditions.
- 65 This document is subject to change without notice.

All rights including industrial property rights and all rights of disposal such as copying and passing to third parties reserved.

Technical Specification	PSI5	4 / 65
	Peripheral Sensor Interface – Base Standard	V2.3

2 Definition of Terms

2.1 Glossary

Table 1: Glossary

Term	Definition
Complex sensor cluster	Single connecting component with integrated microcontroller.
Cycle	Complete instance of the PSI5 communication structure that is periodically repeated. For example, In a synchronous communication scheme a cycle consists of a sync pulse followed by all sensor responses and the necessary idle time
Data Range	Range of values within the payloads data region A allocated for initialization, status & error messages and sensor output signal
Data Region	Part of the payload involved in the transmission of data
Frame	Ensemble of communication bits including: payload, start and error detection bits.
Payload	Part of the data frame involved in the transmission of data, status, frame control or messaging bits
Sensor	Single connecting component with one sensing element.
Sensor cluster	Single connecting component with more than one sensing element.
Serial Channel	Additional messaging option available for sensor to ECU communication by using two optional bits in each data frame, more specifically in each payload.
Serial Data Frame	Ensemble of communication bits for the serial channel comprising data, identification, configuration, cyclic redundancy and reserved bits.
Slot	Time allocation of a frame within a cycle

Technical Specification	PSI5 Peripheral Sensor Interface – Base Standard	5 / 65
		V2.3

2.2 Symbols / Parameters

2.2.1 General Parameters

Table 2: Symbol definitions – ECU side

Symbol / Parameter	Definition
V_{CE}	ECU output voltage present at the ECU socket pins under all conditions including dynamic load such as noise or line effects
$V_{CE,BASE}$	ECU mean output voltage present at the ECU socket pins without communication ($\Delta I_S=0$) and without synchronization pulse (static)
V_E	ECU internal supply voltage
V_{t0}	Sync slope reference voltage referenced to $V_{CE,BASE}$
V_{i2}	Sync signal sustain voltage referenced to $V_{CE,BASE}$
$I_{E,LOW}$	Interface quiescent current tracking at ECU = $\sum I_{S, LOW}$
$I_{E,LIMIT}$	ECU current limitation
$I_{E,LIMIT,dyn.}$	Dynamic ECU current limitation
$\sum \Delta(I_{S, LOW})$	Total interface quiescent current signal noise limit, i.e. sum of all sensor quiescent current signal noises of all bus participants
$L_D (NEW)$	Dynamic Load, i.e. time that the ECU should be able to provide the current $I_{E,LIMIT,dyn.}$
R_E	ECU total internal resistance $R_E = R_{E1} + R_{E2}$
C_E	ECU total internal capacitance $C_E = C_{E1} + C_{E2}$
C_{E1}	ECU internal capacitance
C_{E2}	ECU capacitance at ECU socket pins

Technical Specification	PSI5 Peripheral Sensor Interface – Base Standard	6 / 65
		V2.3

Table 3: Symbol definitions – Sensor side

Symbol / Parameter	Definition
V_{SS}	Sensor input, sensor supply voltage present at the sensor socket pins including dynamic load, such as voltage ripple and noise
$V_{SS,BASE}$	Mean voltage present at sensor socket pins without communication ($\Delta I_S=0$) and without synchronization pulse (static)
V_{TRIG}	Synchronization pulse sensor trigger level threshold referenced to $V_{SS,BASE}$
V_{EMC}	Margin for voltage variations of the signal on the interface line due to EMC effects
I_S	Quiescent current present at the sensor socket pins
$ dI_S/dt $	Sensor quiescent current drift rate
ΔI_S	Sink current $\Delta I_S = I_{S,HIGH} - I_{S,LOW}$ used for sensor to ECU communication
$\Delta(I_{S,LOW})$	Interface quiescent current signal noise limit at single sensor
$I_{S,LOW}$	Current 'low' level ($I_{S,LOW}$) is represented by the quiescent current present at the sensor socket pins.
$I_{S,HIGH}$	Current 'high' level ($I_{S,HIGH}$) generated by the increased current sink at the sensor socket pins ($I_{S,LOW} + \Delta I_S$).
R_S	Sensor equivalent internal resistance at sensor pins
C_S	Sensor equivalent internal capacitance at sensor pins

2.2.2 Communication Parameters

Table 4: Symbol definitions – ECU to sensor communication

Symbol / Parameter	Definition
T_{Sync}	Duration of sync period
t_0	Reference time base; Begin of phase 2 sync slope
t_1	Sync signal earliest start; Delta current less than 2mA; Begin of phase 1 sync start
t_2	Sync signal sustain start @ V_{I2} ; Begin of phase 3 sync sustain
t_3^0	Sync signal sustain time; For short sync pulse [0]
t_4^0	Discharge time; For short sync pulse [0]
t_3^1	Sync signal sustain time; For long sync pulse [1]
t_4^1	Discharge time; For long sync pulse [1]

Technical Specification	PSI5	7 / 65
	Peripheral Sensor Interface – Base Standard	V2.3

Table 5: Symbol definitions – Sensor to ECU communication

Symbol / Parameter	Definition
T_{rise}	Rise time between 20% up to 80% in sink current slope
T_{fall}	Fall time between 80% down to 20% in sink current slope
T_{Bit}	Bit time for a single bit
T_{Gap}	Minimum gap time which must be guaranteed between two successive data frames
t_{TRIG}	Nominal trigger detection time referenced to sensor timebase
T_{TRIG}	Trigger detection window to detect the sync pulse = $t_{TRIG,max} + T_{tol_detect} + T_{EMC}$
T_{tol_detect}	Tolerance time of internal trigger detection delay at sensor
T_{EMC}	Variation time of the signal on the interface line due to EMC
t_{nES}	Earliest start of frame, slot n; this is the earliest time when the transceiver or any other sensor on the bus can expect that the frame no. n begins.
t_{nNS}	Nominal start of frame, slot n; this is the nominal time when the sender (sensor) transmits data according to its own internal clock. It is the nominal time when the transceiver or any other sensor on the bus can expect that the frame, slot no. n begins.
$t_{nNS, prog}$	Nominal start value of frame, slot n that is programmed to the the sensor. It is derived from t_{nNS} by rounding up to the next discretisation value.
t_{nLS}	Latest start of frame, slot n, this is the latest time when the transceiver or any other sensor on the bus can expect that the frame, slot no. n begins.
t_{nEE}	Earliest end of frame, slot n, this is the earliest time when the transceiver or any other sensor on the bus can expect that the frame, slot no. n is over.
t_{nNE}	Nominal end of frame, slot n
t_{nLE}	Latest end of frame, slot n, this is the latest time when the transceiver or any other sensor on the bus can expect that the frame, slot no. n is over.
$t_{Slot 1 Start}$	Earliest start of first sensor data word
$T_{Slot,n}$	Maximum length of frame, slot n.
M^n	No. of bits including start, data and parity or CRC bits of frame, slot n.
N	No. of time slots within one sync cycle
CT^n	Clock tolerance of the transmitter (sensor) sending the frame no. n

2.2.3 Supply Line and Bus Parameters

Table 6: Symbol definitions – Supply Line

Symbol / Parameter	Definition
R_W	Wire resistance (feed & return)
$R_{W/2}$	single wire resistance

Technical Specification	PSI5 Peripheral Sensor Interface – Base Standard	8 / 65
		V2.3

Symbol / Parameter	Definition
R_{CE}	ECU connector resistance
R_{CS}	Sensor connector resistance
C_W	Wire capacitance (feed & return)
L_W	Wire inductance (feed & return)
$L_{W/2}$	single wire inductance

Table 7: Symbol definitions – Bus

Symbol / Parameter	Definition
$R_{W,Total}$	Overall line resistance in asynchronous mode or for each wire 'n' in parallel bus mode sum of ECU connector resistance, wire resistance and sensor connector resistances
C_B	Bus capacitance $\sum C_S$
C_{BUS}	Overall capacitive bus load $C_{BUS} = C_E + C_B$; C_W not included
C_L	Bus load capacitance at device under test
$\sum(L_W)$	Bus inductance; sum of all wire inductances
N_S	Number of sensors in bus

2.3 Acronyms, Abbreviations

Table 8: Acronyms, Abbreviations

Symbol / Parameter	Definition
ASIC	Application Specific Integrated Circuit
ECU	Electronic Control Unit
CRC	Cyclic redundancy check
LSB	Least significant bit
MSB	Most significant bit
DUT	Device Under Test

3 Data Link Layer

3.1 Sensor to ECU Communication

3.1.1 Data Frames

66 The data frames are sent periodically from the sensor to the ECU. A minimum gap time T_{Gap} larger than one
67 maximum bit duration T_{Bit} is required between two data frames. Each data frame consists of p bits containing

- 68 • two start bits (S1 and S2), always coded as “0”
- 69 • one parity bit (P) with even parity or alternatively 3 CRC bits (C0, C1, C2), and
- 70 • a payload (D0 ... D[k-1]) with $k = 10.. 28$ bit.

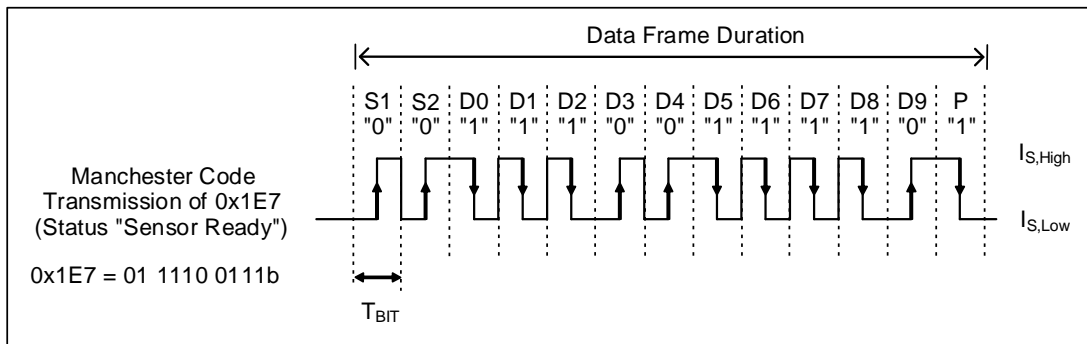

Figure 1: Example of a data frame with 10 data bits (D0-D9), 2 start bits (S1,S2) and one parity bit (P).

71 It follows that the total length of a data frame is $p = k+3$ data bits (in case of frames with parity bit) or
72 $p = k+5$ data bits (in case of frames with CRC). Data bits are transmitted LSB first. The parity or CRC check
73 bits cover the bits of the entire payload with a variable length of $k = 10... 28$ bits (with 1-bit granularity).

3.1.2 Data Frame Format

74 The payload of the data frame may contain one or more fields.

75 One mandatory:

- 76 • Data Region A $A0 \dots A[n-1]$
77 (scalable $n = 10...24$ with 1-bit granularity)

78 And additional optional fields:

- 79 • Data Region B with data bits $B0 \dots B[m-1]$
80 (optional 0, or scalable $m = 1 \dots 12$ bit with 1-bit granularity)
- 81 • Sensor status (error flag) $E0 \dots E[r-1]$ (optional 0, 1 or 2 bit)
- 82 • Frame control $F0, \dots F[q-1]$ (optional 0, 1, 2, 3 or 4 bit)
83 (denotes type of frame/data content, or identifies the sensor)

84 • Serial messaging channel M0, M1 (optional 0 or 2 bit, see also Chapter 3.1.4)

85 Each optional field can be omitted in total or varied in bit length, but, if applied, the specific hierarchy of the
86 fields must be kept as shown in Figure 2.

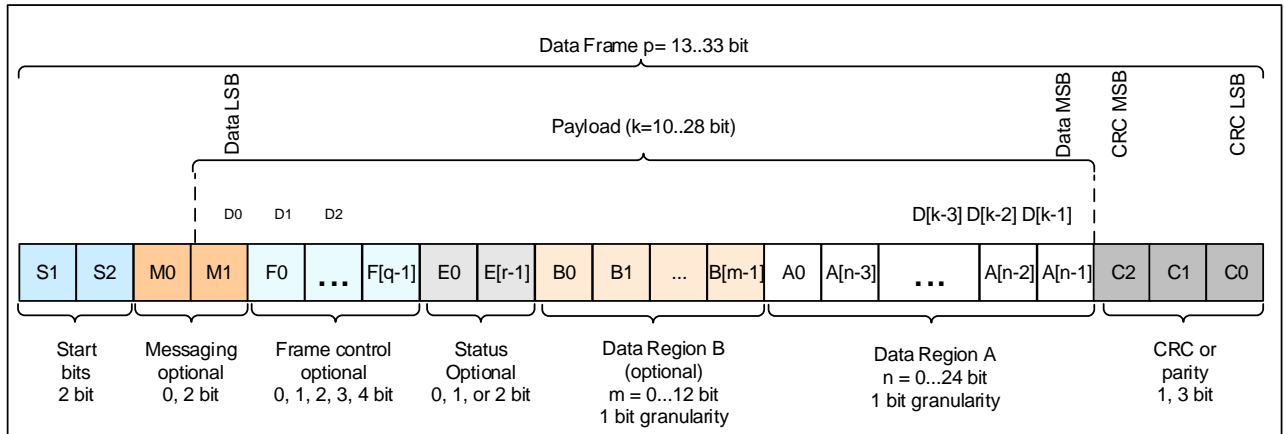

Figure 2: Different parts of the PSI5 data frame

Table 9: Different parts of the payload

Bits	Function	Number of bits	Comment
M0, M1	Messaging	0, 2	Serial messaging channel (optional)
F0 ... F[q-1]	Frame control	0, 1, 2, 3, 4	(optional)
E0 ... E[r-1]	Status	0, 1, 2	(optional)
B0 ... B[m-1]	Data	0, 1, 2, ..., 12	Data Region B (optional)
A0 ... A[n-1]	Data	10, ..., 24	Data Region A (mandatory)

3.1.3 Scaling of Sensor Output (for data words longer than 10 bit)

87 The sensor output signal range scales with the data word length n , whereas status and initialization data words
88 for frames with a payload data region of more than 10 bits still are sent in 10 bit codes of data range 2 and 3.
89 Hence, during Initialization with the data range method, the first 10 MSB bits of data are always used for
90 signaling as defined in Chapter 5.2. The remaining data bits of the payload (either $A[0]...A[n-10]$ or an optional
91 Data Region B) are free to use.

92 The following parts of the payload are not affected by signaling range definition:

- 93 • Remaining bits above 10 of Data Region A ($A[0]...A[n-10]$)
- 94 • Data Region B (optional)
- 95 • Serial messaging Channels (optional)
- 96 • Frame control (optional)
- 97 • Status (optional)

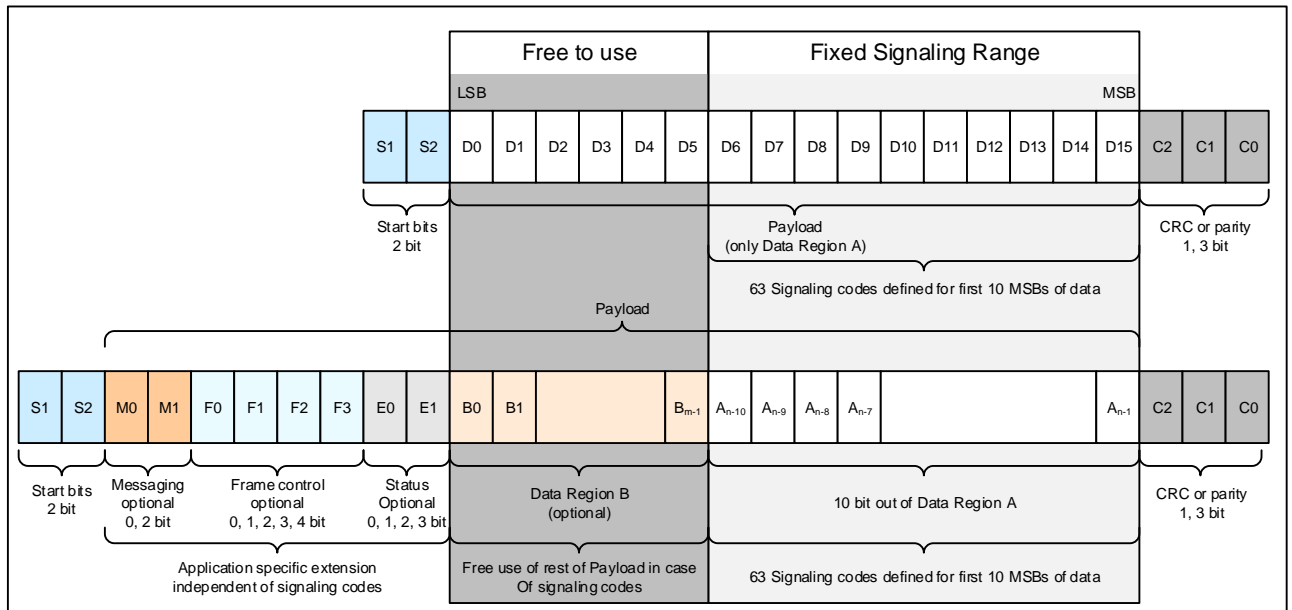

Figure 3: Scaling of data range

3.1.4 Serial Channel

98 In addition to Data Regions A and B, information can be sent via a serial channel. In this case, the serial
99 message frame stretches over 18 consecutive PSI5 data messages from the transmitter as shown below. All
100 18 frames must be successfully transmitted for the serial value to be received. The messaging bit M1 of sensor
101 frame No. 8 determines the serial format (12bit data field with 8bit ID or 16bit data field with 4bit ID). In
102 synchronous operation the serial data frame, or its constituent messaging bits, respectively, is assigned to the
103 related time slot of the corresponding data frame.

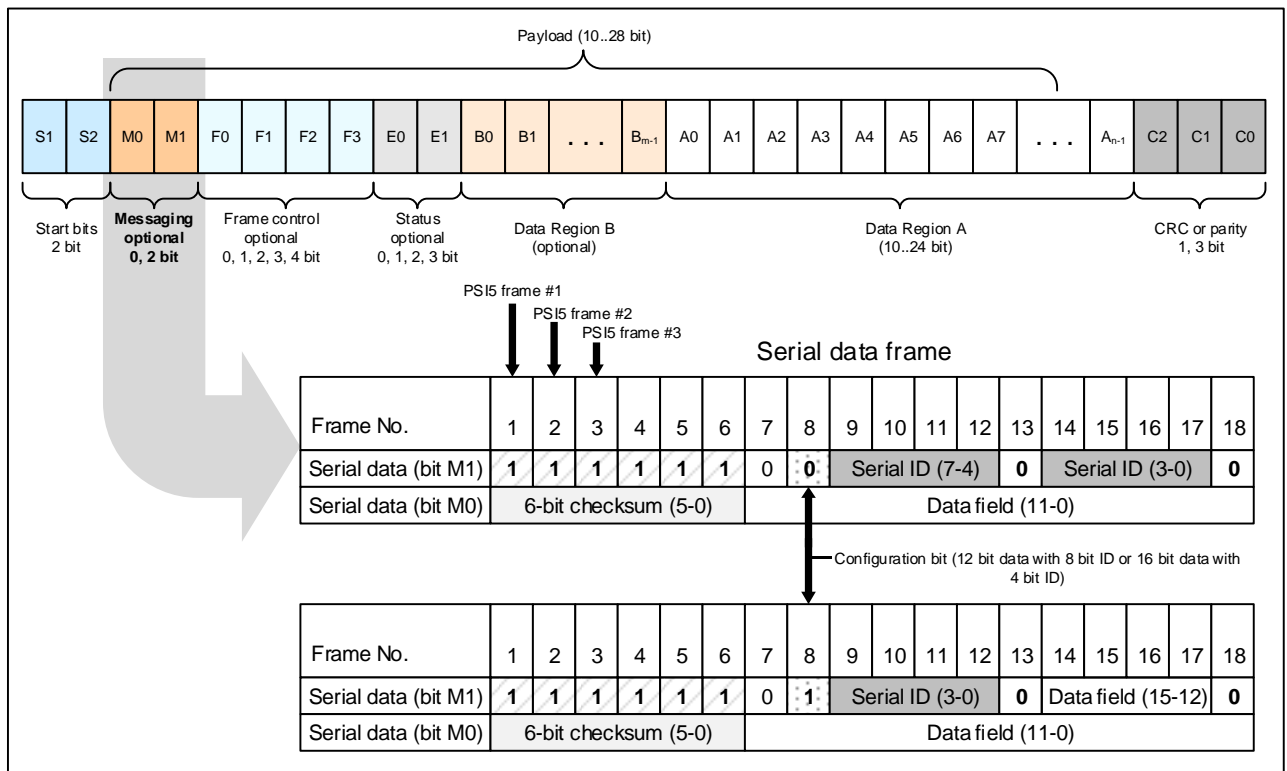

Figure 4: Serial data frame generated by the two messaging bits of the sensor data frame (messaging channel)

3.2 ECU to Sensor Communication

3.2.1 Data Frames

104 The frames for the ECU to sensor communication are composed by

- 105 • A specific start condition, enabling secure detection of the frame start even after loss of synchronization
- 106 • A data field
- 107 • A checksum to ensure data integrity

108 Transmission of a correct ECU to Sensor data frame does not have to be acknowledged in general. However,
 109 if required by the application, the sensor may send an optional response to the ECU by either transmitting a
 110 return code and return data out of the reserved data range area or via the serial channel's messaging bits.

111 ECU to Sensor data frames are structured as described in following chapters. They are applied in different
 112 ways for the two different bit coding method in use (Tooth Gap or Pulse Width method). A combined usage of
 113 bit coding method and their respective frame types is not allowed in order to ensure safe data recognition.
 114 Specific regulations must be given in the corresponding Substandards or specific product specifications.

3.2.2 Frame Formats - Tooth Gap method

115 The Tooth Gap method is limited to usage of data frame formats 1-3. Frame formats 1-3 are composed by
 116 three start bits, a data field containing the sensor address, function code and data and a three bit CRC. Sensor
 117 response may be sent in data range format within the following two or three sync periods. Three data field
 118 lengths are available, "short", "long" and "xlong".

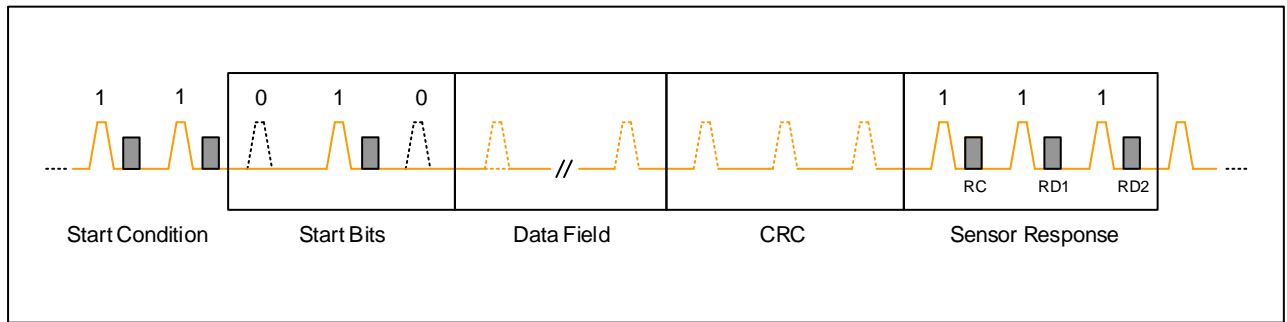

Figure 5: ECU to sensor communication with Tooth Gap method

119 The start condition for an ECU to sensor communication consists of either at least five consecutive logical
 120 zeros or at least 31 consecutive logical ones. The sensor responds with the standard sensor to ECU current
 121 communication in its corresponding time slot. “Sync Bits” (logical “1”) are introduced at each fourth bit position
 122 in order to ensure a differentiation between data content and start condition and to enable sensor
 123 synchronization when using the tooth gap method. The data frame length is defined by the content of the
 124 Sensor Address (SAdr) and the function Codes (FC) as shown in Figure 6. The calculation of the three bit
 125 checksum is given in Chapter 3.3.2.

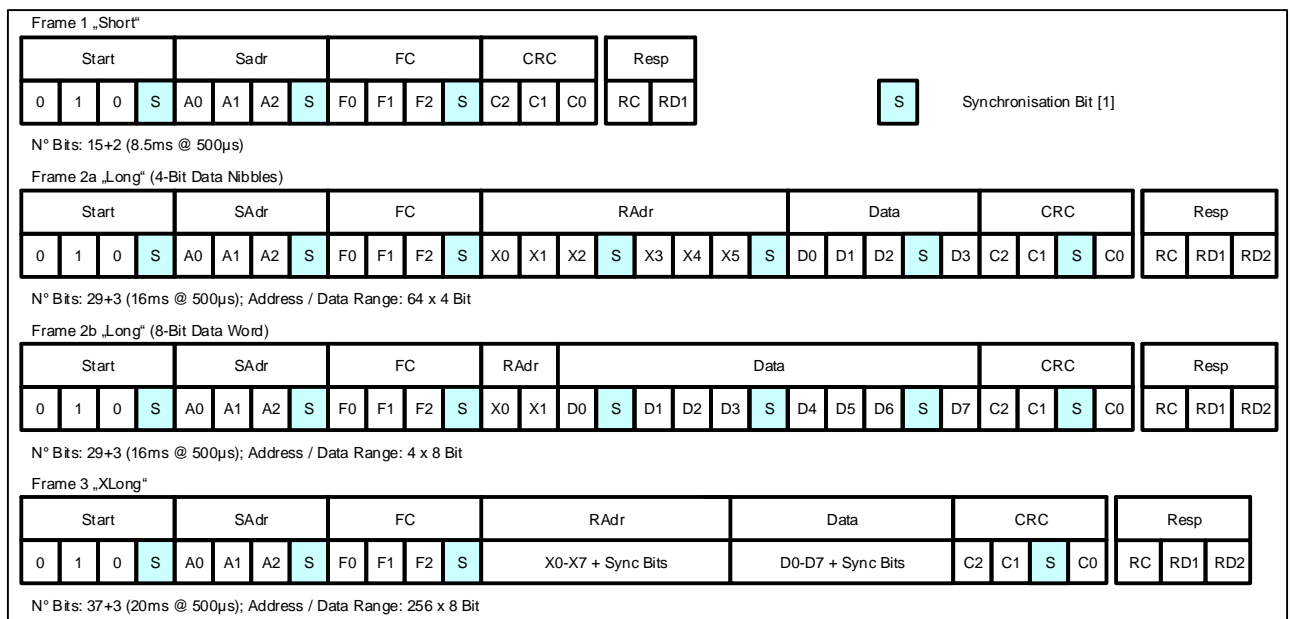

Figure 6: Data frames 1-3 for ECU to sensor communication with Tooth Gap method

3.2.3 Frame Formats – Pulse Width method

126 Pulse Width method uses frame format 4. Data frame 4 is composed by nine start bits, a three bit sensor
 127 address field, a configuration bit, a 20-bit data field containing application specific data and a six bit CRC.
 128 “Stuffing Bits” (logical “0”) are introduced at each seventh bit position (eight bit position for start region) in order
 129 to ensure a differentiation between data content and frame start. Transmission of a correct ECU to Sensor
 130 data frame does not have to be acknowledged in general. However, if required by the application, the sensor
 131 may send a response to the ECU by either transmitting a return code and return data out of the reserved data

132 range area or via the serial channel's messaging bits. All function codes and frame data content of frame
 133 formats 1-3 can also be transmitted with frame format 4 and Pulse Width method, as describes in the next
 134 section.

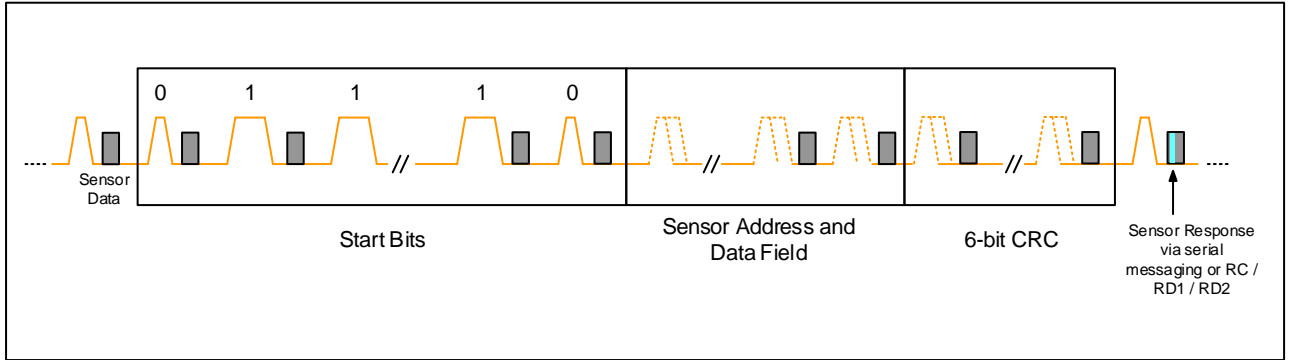

Figure 7: ECU to sensor communication with Pulse Width method

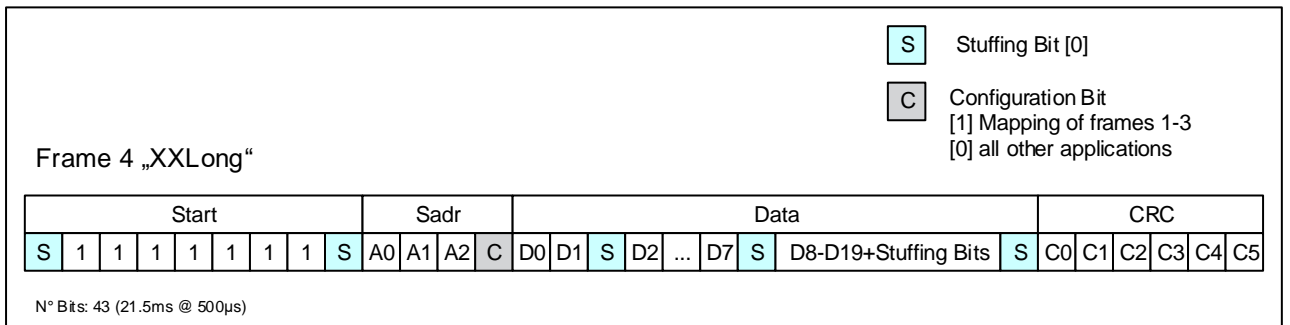

Figure 8: Data frame 4 for ECU to sensor communication with Pulse Width method

3.2.4 Mapping of Data frames for Pulse Width method

135 In case the function codes as defined in Chapter 5.3 shall be used in combination with frame 4 and Pulse
 136 Width method, they shall be mapped as shown below.

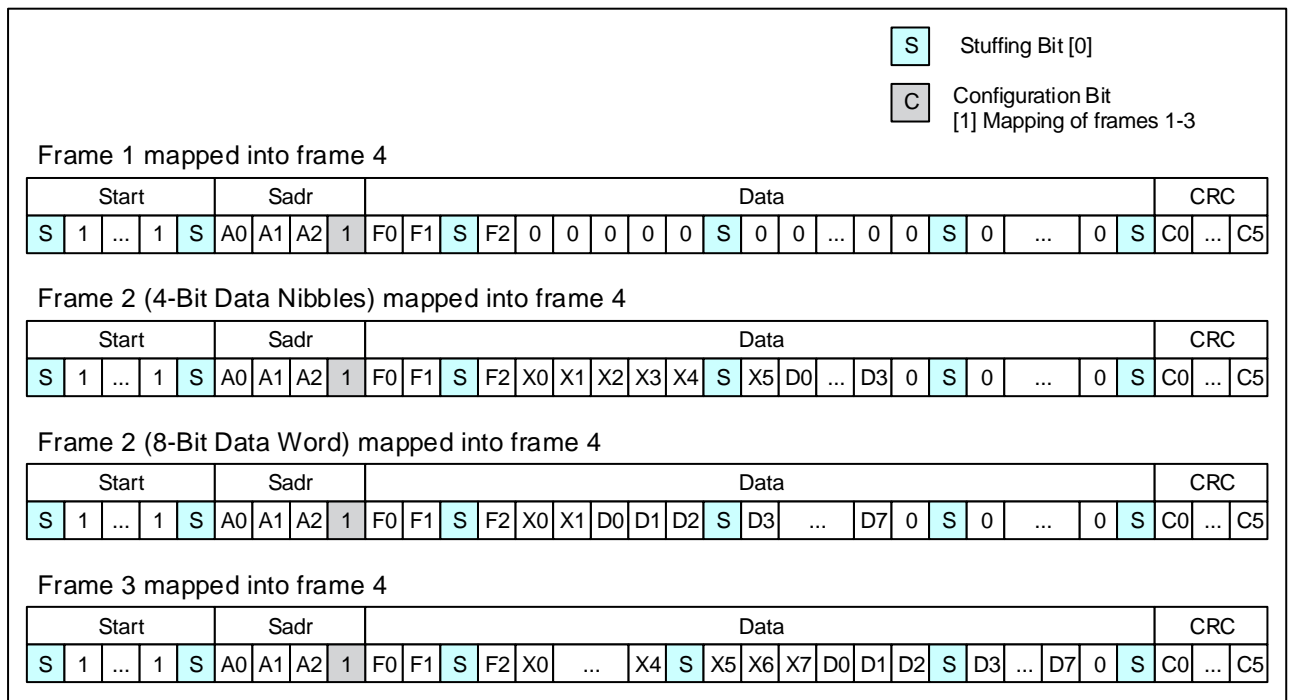

Figure 9: Mapping of frames 1-3 into frame 4

3.3 Error Detection

137 Error detection is embedded into all messaging schemes within PSI5. For sensor to ECU communication a
 138 single bit even parity (for example for 10 bit data words) or a 3 bit CRC (intended for longer data words) is
 139 used. In this case the 3 bit CRC comprises all payload bits (D[0] ... D[k-1], see Figure 10). In addition the 3 bit
 140 CRC is also used for ECU to sensor communication for those frames using tooth-gap method. For both the
 141 serial channel in sensor to ECU communication and the pulse width method in ECU to sensor communication
 142 a 6 bit CRC is used.

3.3.1 Parity Bit

143 One error detection alternative is the use of a parity bit to verify the payload content. Here, even parity is used.
 144 It is intended for use in shorter data words, i.e. 10 bit data words, and excludes the start bits.

3.3.2 3 bit CRC

145 The generator polynomial of the CRC is $g(x) = x^3 + x + 1$ with a binary CRC initialization value "111" (MSB first)
 146 and the data bits extended by three zeros (as MSBs). This augmented data word shall be fed (LSB first) into
 147 the shift registers of the CRC check. Start bits are ignored in this check. When the last zero of the augmentation
 148 is pending on the input adder, the shift registers contain the CRC checksum. These three check bits shall be
 149 transmitted in reverse order (MSB first: C2, C1, C0).

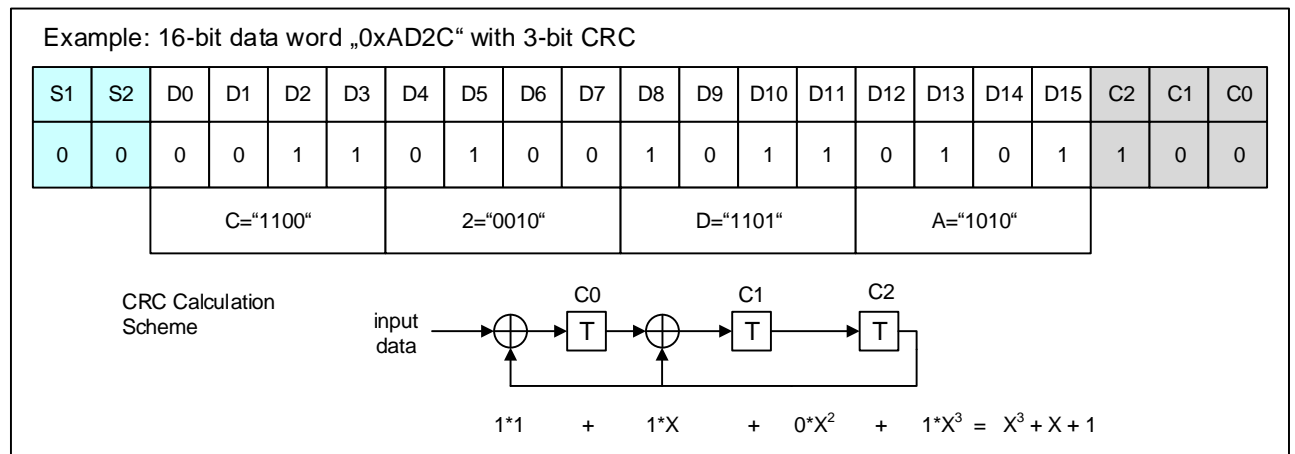

Figure 10: Bit Data word example with 3-Bit CRC

3.3.3 6 bit CRC

150 The generator polynomial of the 6bit checksum is $g(x) = x^6 + x^4 + x^3 + 1$ with a binary initialization value "010101"
 151 (MSB first). In the case of sensor to ECU serial communication the CRC value is derived from the serial
 152 messaging contents of sensor frame 7 to 18, the bits are read into a newly generated message data word
 153 starting with the serial Data bit M0 of sensor frame 7 and ending with the serial data bit M1 of sensor frame
 154 18. The reading order is illustrated in Figure 11. For ECU to sensor communication the start bits and stuffing
 155 bits are ignored in this check.
 156 For CRC generation the transmitter extends the message data by six zeros. This augmented data word shall
 157 be fed (LSB first) into the shift registers of the CRC check. When the last zero of the augmentation is pending
 158 on the input adder, the shift registers contain the CRC checksum. For sensor to ECU serial communication
 159 these six check bits shall be transmitted MSB first [C5, C4, ... C0]. An example is given in Figure 12. In the
 160 case of ECU to sensor communication via pulse width method these six check bits shall be transmitted LSB
 161 first [C0, C1 .. C5].

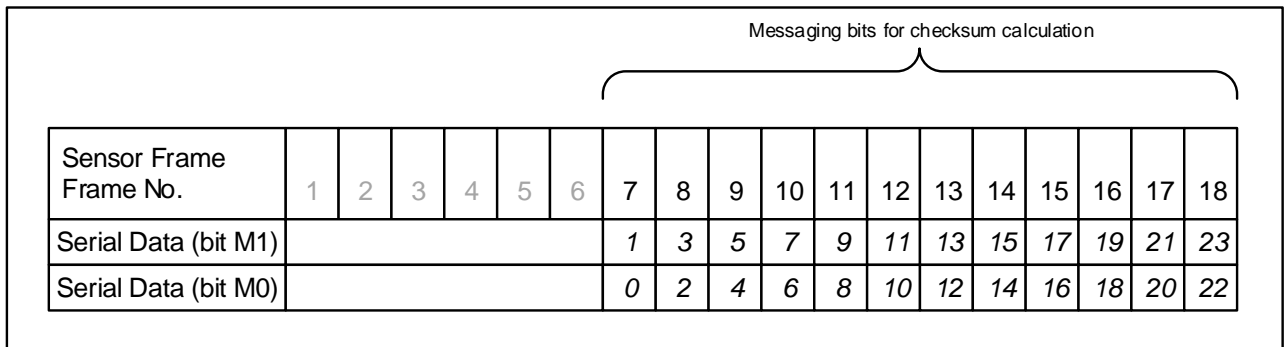

Figure 11: Reading order for checksum generation in sensor to ECU serial communication

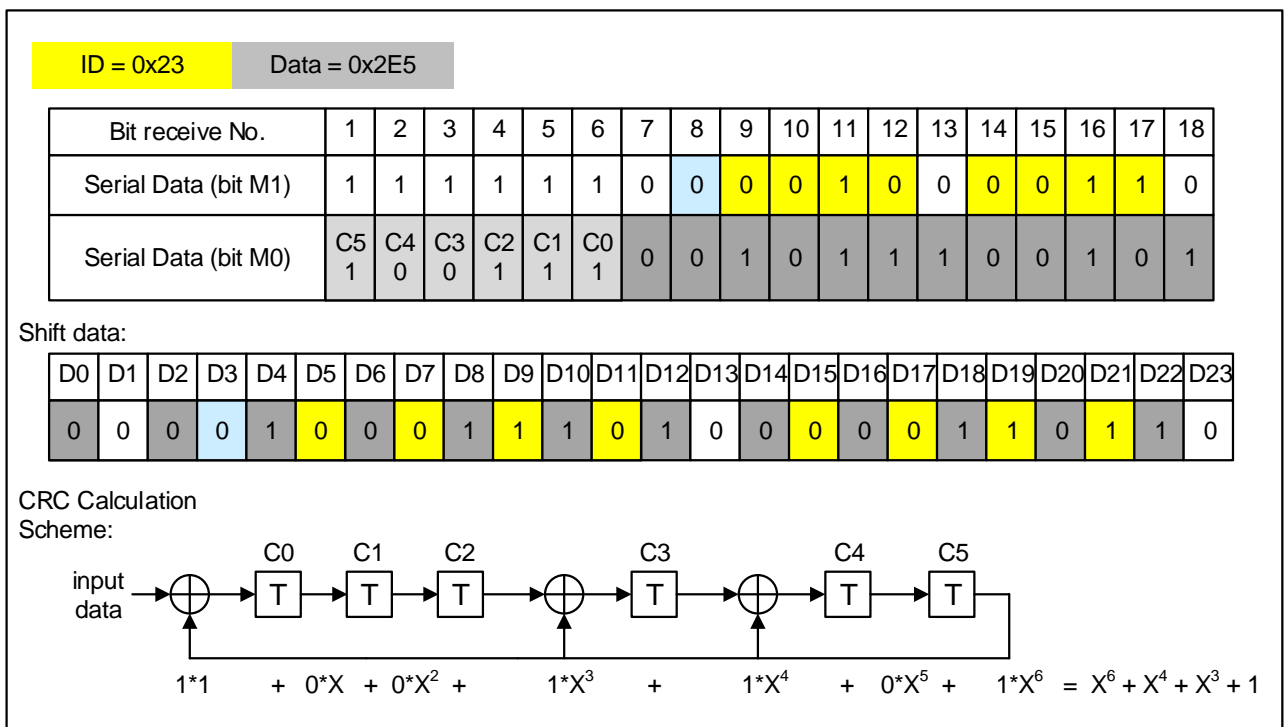

Figure 12: Example for checksum generation, 12-Bit data field, 8-Bit message ID and 6-Bit CRC for sensor to ECU serial communication channel

4 Physical Layer

4.1 General

162 The sensors are connected to the ECU by just two wires, using the same lines for power supply and data
 163 transmission. The ECU integrated transceiver provides a pre-regulated voltage to the sensors and reads in
 164 the transmitted sensor data. The transmission of sensor data to the ECU is done by the means of current
 165 modulation. An optional pulse modulation on the supply voltage from the ECU to the sensors can be used to
 166 synchronize sensor data transmission and to transmit data from the ECU to the sensor. For 125kbps all
 167 maximum and minimum values are specified. Implementations at other data rates, such as 189 Kbps are
 168 however possible but have to be validated on system level. Large cable lengths / inductances may require
 169 appropriate selection of sensor and ECU capacitance values and / or additional damping measures.

4.2 Supply Line Model

170 PSI5 usually uses twisted pair lines which are modeled as shown in Figure 13. Parameter specification is done
 171 separately for the different system configurations. All parameters are based on a maximum supply line length
 172 of 12m under assumption of standard CAN cable with a maximum inductance of $0.72\mu\text{H/m}$ and maximum
 173 capacitance of 50 pF/m . This maximum length, however, is only an indication. Depending on the wiring harness
 174 and system configuration the maximum length might vary.

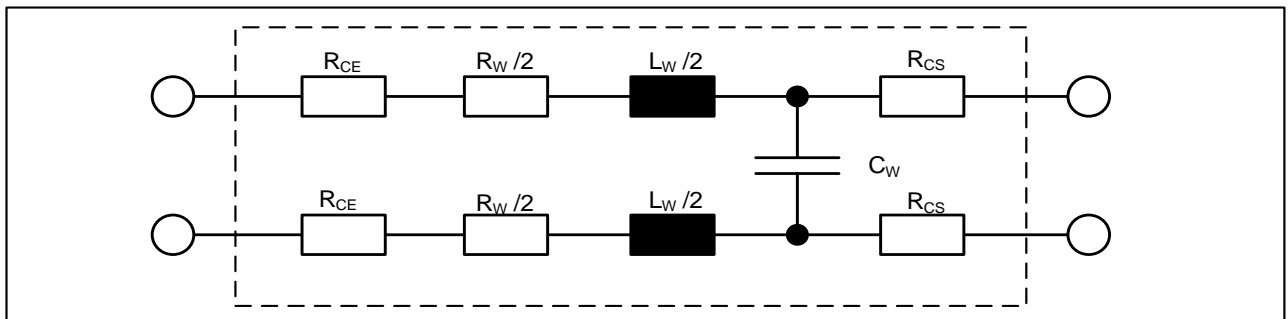

Figure 13: Supply line model for PSI5

Table 10: Parameter specification for supply line model

N°	Parameter	Symbol	Conditions/Remark	Min	Typ	Max	Unit
1	ECU Connector resistance	R_{CE}			(0.2)		Ω
2	Sensor Connector resistance	R_{CS}			(0.2)		Ω
3	Single wire resistance	$R_{W/2}$			(0.5)		Ω
4	Overall line resistance incl. wire & connector	$R_{W,Total}$	$2 * (R_{CE} + R_{W/2} + R_{CS})$	0.1		2.5	Ω
5	Wire inductance	L_W	$2 * (L_W / 2)$			8.7	μH
6	Wire capacitance	C_W				600.0	pF

4.3 Single Sensor, Point to Point Topologies

4.3.1 Single Sensor, Point to Point Asynchronous Topologies (PSI5-A)

175 PSI5-A describes a point-to-point connection for unidirectional, asynchronous data transmission.
 176 Each sensor is connected to the ECU by two wires to a dedicated interface of the transceiver. After switching
 177 on the power supply, the sensor starts transmitting data to the ECU periodically. Timing and repetition rate of
 178 the data transmission are controlled by the sensor.

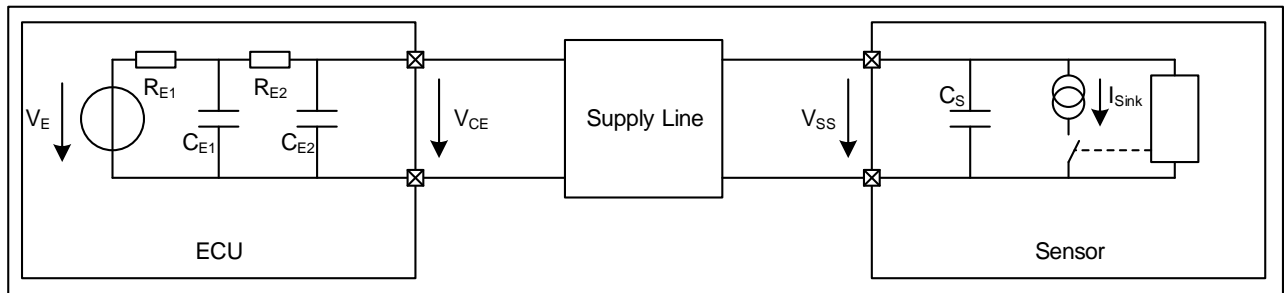

Figure 14: Single sensor configuration (simplified diagram)

4.3.2 Parameter Specification for Single Sensor Configuration

Table 11: Parameter specification for single sensor configuration

N°	Parameter	Symbol	Conditions/Remark	Min	Typ	Max	Unit
1	ECU total internal capacitance $C_E = C_{E1} + C_{E2}$	C_E		6.0		47	nF
2	Sensor equivalent internal capacitance	C_S	@ 10...200kHz	6.0		47	nF
3			@ 200kHz...2MHz	1.32		47	nF
4	ECU total internal resistance	R_E	Standard	5		12.5	Ω
5	$R_E = R_{E1} + R_{E2}$		Advanced	5		9.5	Ω
6	Sensor equivalent internal resistance	R_S		2.5			Ω

4.4 Multi Sensor, Bus Topologies

4.4.1 Synchronous Parallel Bus Mode (PSI5-P)

179 PSI5-P describes a bus configuration for synchronous data transmission of one or more sensors connected to
 180 a single interface of the transceiver within the ECU.
 181 Each sensor is connected to the ECU by a separate pair of wires (star topology).

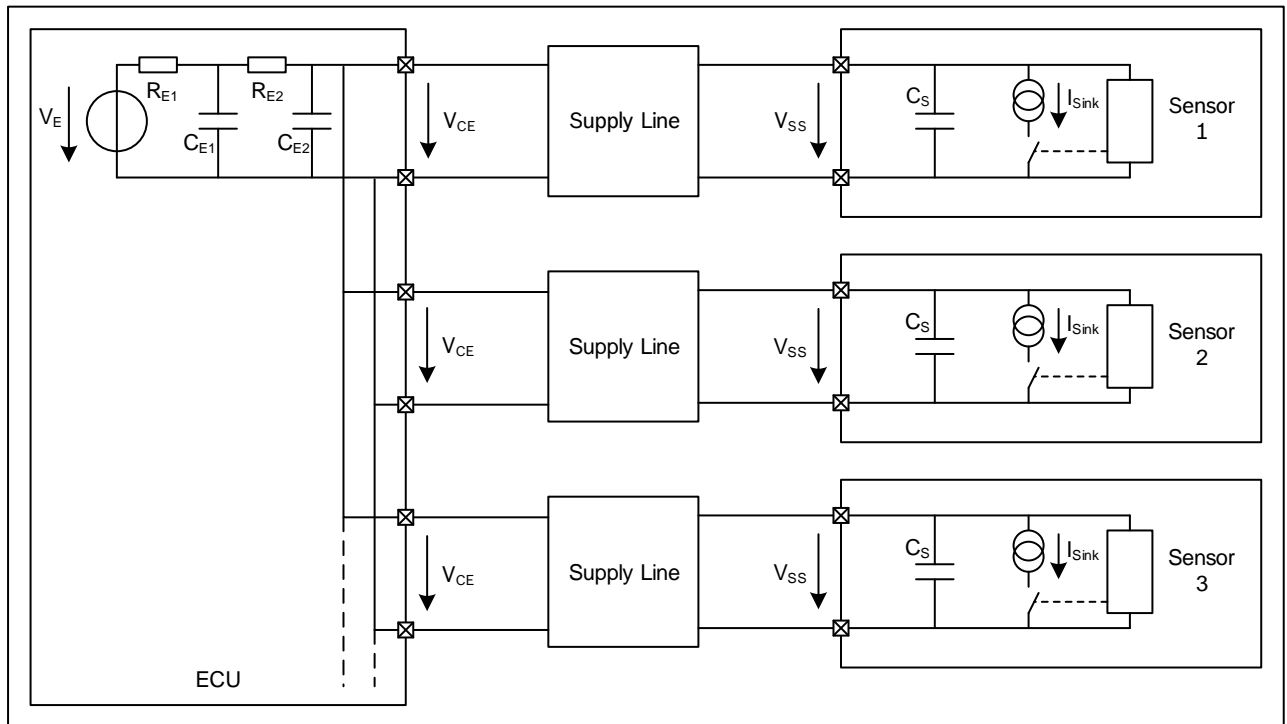

Figure 15: Synchronous parallel bus mode (simplified schematic)

182 In order to provide an interchangeability of different sensor and transceiver components, additional interface
 183 parameters for ECU, sensors, and wiring are specified for this bus mode in Chapter 4.4.4.

4.4.2 Synchronous Universal Bus Mode (PSI5-U)

184 PSI5-U describes a bus configuration for synchronous data transmission of one or more sensors connected
 185 to a single interface of the transceiver within the ECU.

186 The sensors can be connected to the ECU in different wiring topologies including splices or pass-through
 187 configurations. In all cases the total supply line, i.e. sum of all supply lines, shall not exceed the maximum
 188 values given in Table 12.

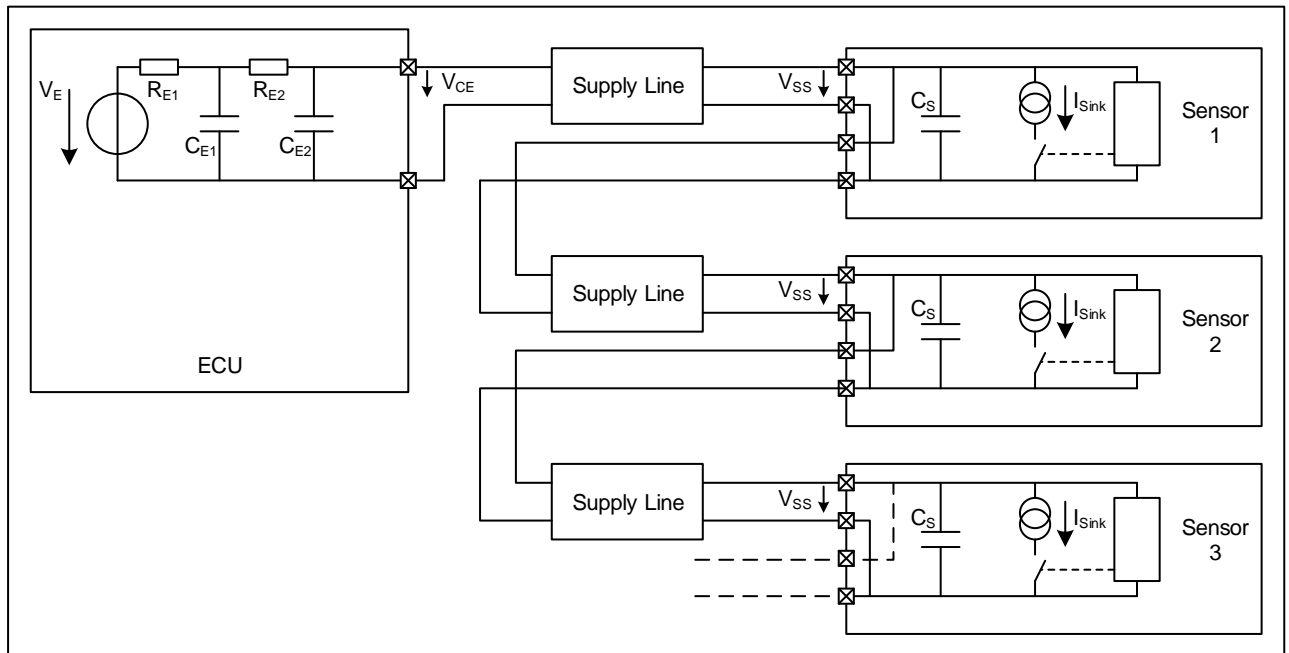

Figure 16: Example for a pass-through configuration (simplified schematic)

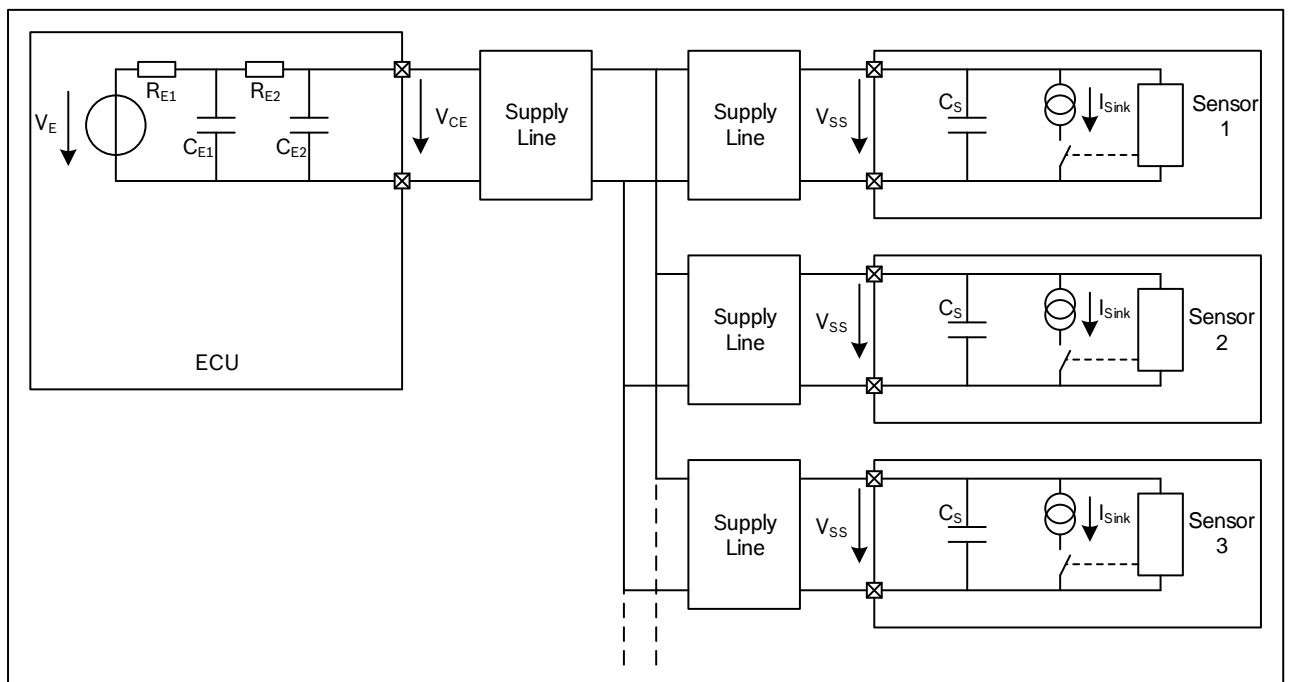

Figure 17: Example for a splice configuration (simplified schematic)

189 The wiring and sensors are considered as a “black box” resulting in a limited interchangeability of sensor and
 190 transceiver components. Interface parameters in Chapter 4.4.4 are given for the ECU and the “black box” only.

4.4.3 Synchronous Daisy Chain Bus Mode (PSI5-D)

191 PSI5-D describes a bus configuration for synchronous data transmission of one or more sensors connected in
 192 a daisy chain configuration to a single interface of the transceiver within the ECU.

193 The required addressing of the sensors during start up is specified in Chapter 5.3.2. Interface parameters for
 194 ECU, sensors, and wiring are specified in Chapter 4.4.4.

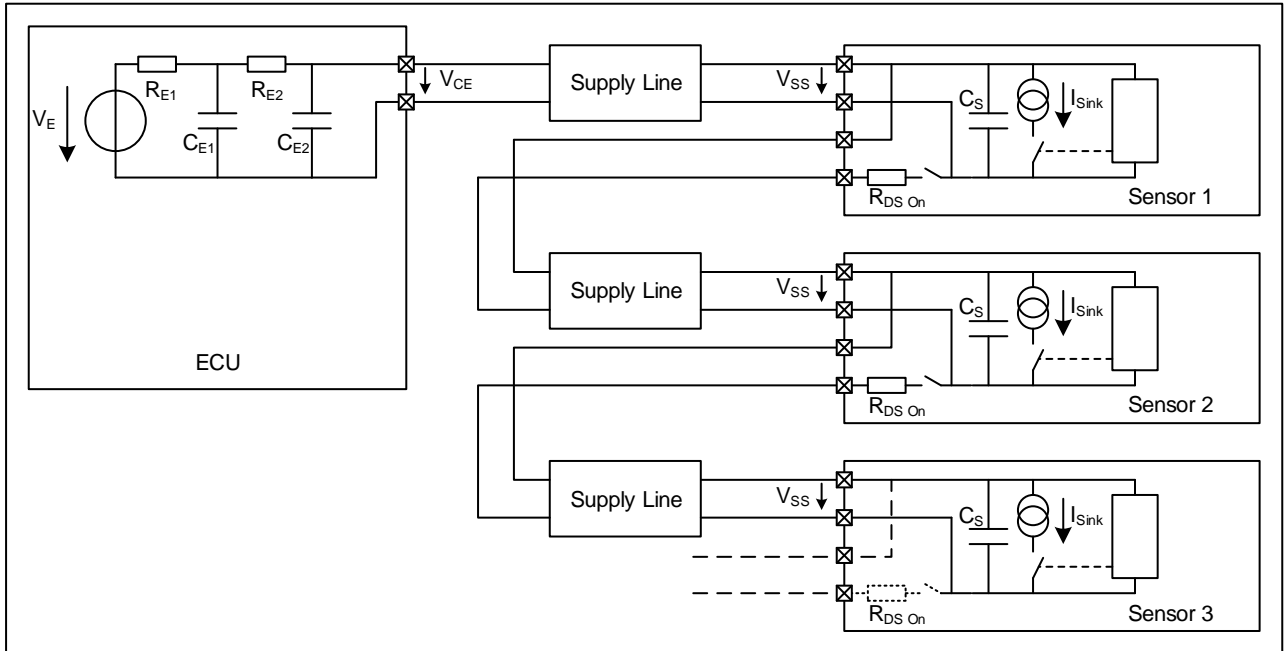

Figure 18: Synchronous daisy chain bus (simplified schematic)

4.4.4 Parameter Specification for Bus Topologies

Table 12: Parameter specification for bus topologies

N°	Parameter	Symbol	Conditions/Remark	Min	Typ	Max	Unit
1*	ECU total internal capacitance $C_E = C_{E1} + C_{E2}$	C_E		15		35	nF
2*	Sensor (equivalent) internal capacitance	C_S	@ 10...200kHz	9		24	nF
3*			@ 200kHz...2MHz	1.32		24	nF
4	Bus capacitance	C_B	$C_B = \sum C_S$	9		72	nF
5*	Overall capacitive bus load	C_{Bus}	$C_{Bus} = C_E + C_B$	24		107	nF
6	ECU total internal resistance	R_E	Standard	5		12.5	Ω
7	$R_E = R_{E1} + R_{E2}$		Advanced	5		9.5	Ω
8	Sensor (equivalent) internal resistance	R_S		2.5			Ω
9	Bus inductance	$\sum(LW)$	Sum of all wire inductance: $\sum(2 * (L_W / 2))$			8.7	μH

195 1*) Damping is required in ECU to limit oscillations on the bus lines.
 196 2-3*) Maximum value for C_S is given for an out of context design; If system integration requires it C_S for single sensors
 197 can be exceeded but max Bus capacitance C_B shall not be violated and system design shall ensure proper
 198 signal behavior
 199 5*) Wire capacitance C_W not included due to negligible value

4.5 Sensor to ECU Communication

200 Data transmission from the sensor to the ECU is realized by current modulation of the power supply by a
 201 sensor internal controlled source. Resulting supply line current oscillations are damped by the ECU and sensor
 202 input impedances. An exemplary sensor to ECU communication is shown in the figure below on the basis of
 203 the sensor current I_S .

- 204 • A "low" level ($I_{S,LOW}$) is represented by the normal (quiescent) current consumption of the sensor.
- 205 • A "high" level ($I_{S,HIGH}$) is generated by an increased current sink of the sensor ($I_{S,LOW} + \Delta I_S$).

206 The current modulation is then detected within the transceiver ASIC as a manchester coded stream, where a
 207 logic "0" is represented by a rising slope and a logic "1" by a falling slope of the current in the middle of T_{Bit}
 208 (see PSI5 data link layer definition).

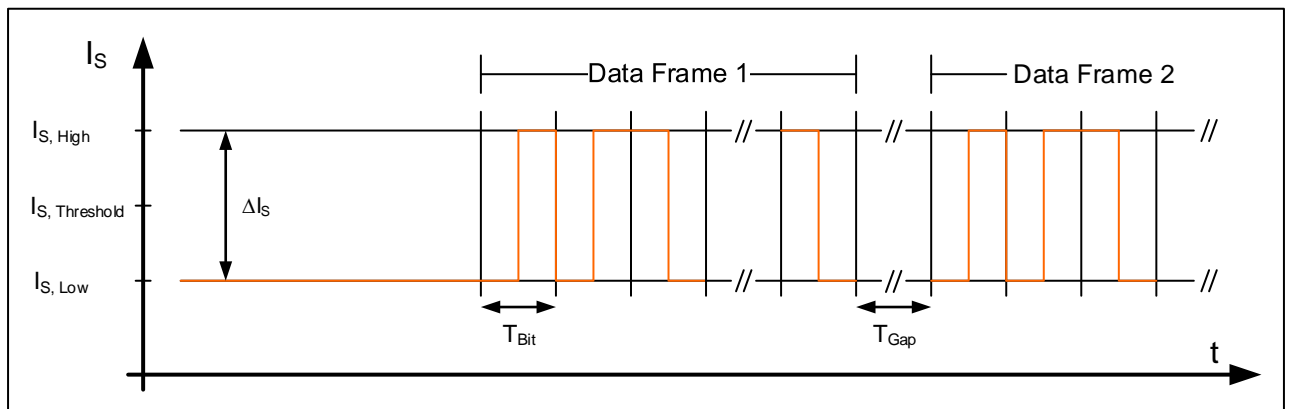

Figure 19: Bit encoding and data frame timing for sensor to ECU communication

Table 13: Parameter specification of sensor to ECU communication (related to the sensor)

N°	Parameter	Symbol	Conditions/Remark	Min	Typ	Max	Unit
1*	Bit time (based on Standard clock tolerance)	T_{Bit}	125kbps mode	7.6	8.0	8.4	μs
2*			189kbps mode	5.0	5.3	5.6	μs
3*	Clock tolerance of the transmitter (sensor)	C_T	Standard			5	%
4*	Sensor clock deviation during data frame (see Substandard)	CD_S	Standard			1	%
5*			Legacy			0.1	%
6	Gap time	T_{Gap}	125kbps mode; $T_{Gap} > T_{Bit}$	8.4			μs
7			189kbps mode; $T_{Gap} > T_{Bit}$	5.6			
8*	Rise Time Current Slope	T_{RISE}	20%..80% (of ΔI_S)	(0.33)		(1.0)	μs
9*	Fall Time Current Slope	T_{FALL}	80%..20% (of ΔI_S)	(0.33)		(1.0)	μs

N°	Parameter	Symbol	Conditions/Remark	Min	Typ	Max	Unit
10*	Mark/Space Ratio	MSR	@ Sensor $(t_{fall, 80} - t_{rise, 20}) / T_{Bit}$ $(t_{fall, 20} - t_{rise, 80}) / T_{Bit}$	47	50	53	%
11	Maximum clock drift rate	ΔC_T				1	%/sec

209 1,2*) corresponding to a standard clock tolerance of the transmitter C_T

210 3*) Advanced clock tolerance refers to tighter clock tolerances needed for longer messages (see Chassis and

211 Safety Substandard).

212 4,5 *) @ maximum temperature gradient and maximum frame length; the overall clock tolerance of the transmitter

213 must not be exceeded.

214 8,9*) Small rise and fall times lead to increased radiated emission. Different definitions may apply for Universal Bus

215 and Daisy Chain Bus. Parameters in brackets are given as a hint for the sensor development. Tighter tolerances

216 might apply to the current sink in the transmitter.)

4.6 ECU to Sensor Communication

217 While the sensor to ECU communication is realized by current signals, voltage modulation on the supply lines

218 is used to communicate with the sensors. The PSI5 “sync signal” is used for the sensor synchronization in all

219 synchronous operation modes and also as physical layer for bidirectional communication.

220 ECU to Sensor communication is performed according to either the so called Tooth Gap or Pulse Width method

221 as defined hereafter.

4.6.1 Tooth Gap method

222 A logical “1” is represented by the presence of a regular (“short”) sync signal, a logical “0” by the absence of

223 the sync signal at the expected time window of the sync signal period. The voltage for a logical “0” must remain

224 below the sync slope reference voltage V_{t0} specified as the sync signal t_0 start condition.

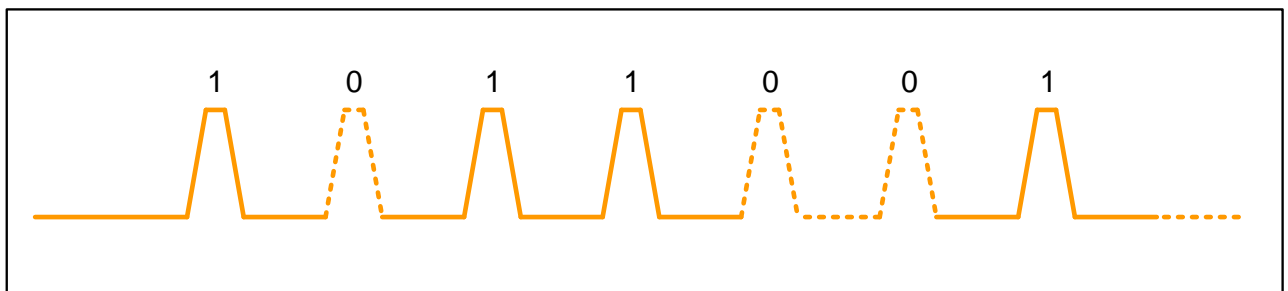

Figure 20: Bit encoding according to the Tooth Gap method

225 This bit encoding method is only applicable with a fixed sync signal period.

4.6.2 Pulse Width method

226 A logical “0” is represented by the presence of the regular (“short”) PSI5 sync signal, a logical “1” by a longer

227 sync signal (see Chapter 4.9)

Technical Specification	PSI5 Peripheral Sensor Interface – Base Standard	25 / 65
		V2.3

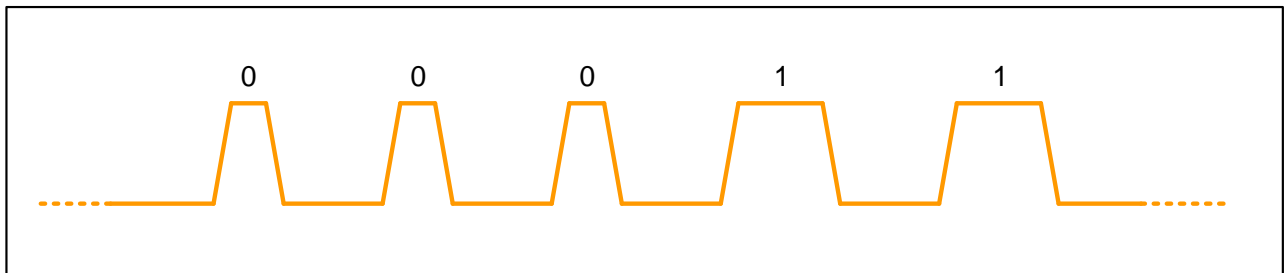

Figure 21: Bit encoding via Pulse Width method

4.7 General Parameters

228 In this section an overview is given of all parameters valid under all operating conditions including temperature
 229 range and life time. Detailed information is given within the corresponding paragraphs of the following pages.

4.7.1 Supply and Communication Parameters Definitions

230 In Figure 22 an overview of the current and voltage behavior for both sensor and ECU is shown during ECU
 231 to sensor and sensor to ECU communication.

232 Current behavior is given in terms of ECU current I_E , measured at the ECU connector pins. Voltage behavior,
 233 on the other hand, is given in terms of supply voltages V_{CE} and V_{SS} , which are the (resulting) voltages at the
 234 ECU / Sensor connector pins. They include static and dynamic effects of the current modulation, where the
 235 dynamic effects are originated in the dynamic sink current ΔI_s through the parasitic supply line (R_w , L_w , C_w)
 236 as well as ECU (C_E) and sensor (C_S) internal elements leading for example to ripple voltages and noise. It
 237 therefore follows that the minimum and maximum supply voltage @ sensor $V_{SS, \min}$ and $V_{SS, \max}$ shall not be
 238 violated during any condition. Additionally, base supply voltages $V_{CE, \text{BASE}}$ and $V_{SS, \text{BASE}}$ are defined as the static
 239 voltages at the ECU and sensor connector pin when no communication is taking place (i.e. no sync pulse or
 240 current modulation). Here, $V_{SS, \text{BASE}}$ is equivalent to $V_{CE, \text{BASE}}$ minus the static supply voltage drops resulting
 241 from interface quiescent current I_{LOW} over the supply line resistances, where additional static voltage drops
 242 over the ECU (R_E) or sensor internal resistors are not included in the base supply voltages $V_{CE, \text{BASE}}$ and $V_{SS, \text{BASE}}$.
 243

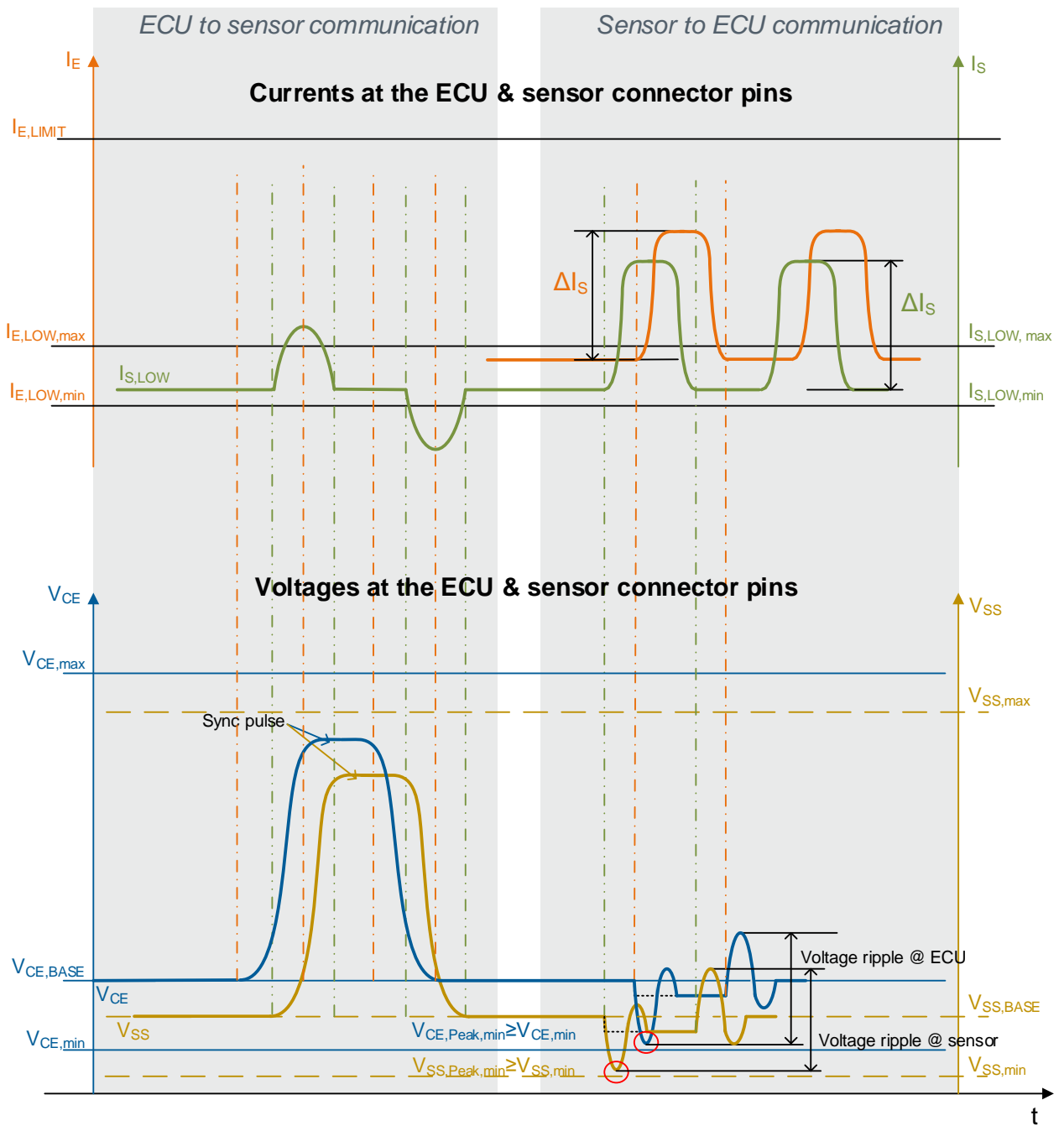

Figure 22: System current and voltage definitions

244 In the table below all voltage and current values are measured at the sensor's connector pins unless otherwise
 245 noted.

Table 14: System parameter specification

N°	Parameter	Symbol	Conditions/Remark	Min	Typ	Max	Unit
1*	Supply Voltage	V _{SS}	Standard Voltage	5.0		16.5	V
2*	@ Sensor		Low Voltage	4.0		16.5	
3*	Base supply voltage	V _{SS, BASE}	Standard Voltage;	5.0		11.0	V

Technical Specification	PSI5 Peripheral Sensor Interface – Base Standard	27 / 65
		V2.3

N°	Parameter	Symbol	Conditions/Remark	Min	Typ	Max	Unit
4*	@ Sensor		Low Voltage	4.0		11.0	
5*	Supply Voltage @ ECU	V_{CE}	Standard Voltage	5.5		16.5	V
6*			Low Voltage	4.2		16.5	
7*			Increased voltage	6.5		16.5	
8*	Base supply voltage @ ECU	$V_{CE, BASE}$	Standard voltage	5.7		11.0	V
9*			Low voltage	4.4		11.0	
10*			Increased voltage	6.7		11.0	V
11	Sink current @ Sensor	ΔI_S	Common mode; $\Delta I_S = I_{S, HIGH} - I_{S, LOW}$	22.0	26.0	30.0	mA
12			Low power mode; $\Delta I_S = I_{S, HIGH} - I_{S, LOW}$	11.0	13.0	15.0	mA
13*	Interface quiescent current @ Sensor	$I_{S, LOW}$	Standard current	4.0		19.0	mA
14			Extended current	4.0		35.0	mA
15*			Daisy chain mode	4.0		12.0	mA
16*	Interface quiescent current tracking @ ECU	$I_{E, LOW} = \sum I_{S, LOW}$	Standard current	4.0		19.0	mA
17*			Extended current	4.0		35.0	mA
18*	Quiescent current drift rate @ Sensor	$ dI_S/dt $	measured after 1st order high-pass filter with corner frequency $f_{C,1}=1\text{Hz}$			10	mA/sec
19*	Current limitation @ ECU	$I_{E, LIMIT}$	Standard current	50.0		105	mA
20*			Extended current	65.0		130	mA
21*	Dynamic current limitation @ ECU	$I_{E, LIMIT, dyn.}$	Standard current with dynamic load condition	65.0			mA
22*			Extended current with dynamic load condition	80.0			mA
23*	signal noise limit @ Sensor (peak to peak, $f_{C,1} = 1\text{Hz} < f < 5\text{MHz} = f_{C,2}$)	$\Delta(I_{S, LOW})$	Standard noise limit	-2		+2	mA
24*			Extended noise limit	-3		+3	mA
25*			Reduced noise limit	-1		+1	mA
26	signal noise limit @ ECU ($\Sigma(\text{Sensors})$)	$\sum \Delta(I_{S, LOW})$	$\text{sqrt}(4 \times \Delta(I_{S, LOW})^2)$			+4	mA

- 246 1, 2*) In any case during normal operation V_{SS} shall not be violated. This includes dynamic effects like ripple voltage
247 and noise.
- 248 7, 10*) Optional increased base supply voltage to overcome additional voltage drops in Universal Bus and Daisy Chain
249 Bus applications.
- 250 5-7*) To be guaranteed by the ECU at the output pins of the ECU under all specified conditions including over- and
251 undershoot due to changes in line load when in Universal Bus Mode and Daisy Chain Bus Mode. Tested as
252 defined in the ECU reference test in Chapter 4.8.1.3.

253 13-15*) When implemented in a bus configuration $I_{S, LOW}$ will determine the number of sensors allowed as limited by the
254 maximum Quiescent current @ECU
255 15*) In Daisy Chain Bus Mode the quiescent current limitations apply for a single sensor.
256 16-17*) Range of tracked current supply for sensor.
257 17*) Extended current range for higher current consumption e.g. in bus or sensor cluster configurations.
258 21, 22*) Dynamic load condition: The ECU must have the capability to provide the current $I_{E, LIMIT, dyn}$ for t_{SET1} . For Daisy
259 Chain Bus Mode this current has to be provided for at least 10ms when a sensor is powered on (see Table 22).
260 23-25*) Parameters denote the sum over all bus participants. I_{LOW} is the (initial and average) quiescent current of the
261 bus. Over lifetime and temperature, the quiescent current may vary but must not exceed the limits for I_{LOW} .
262 Means for an adaptive current threshold may be required in the transceiver in order to cope with varying
263 quiescent currents, especially when connected in bus systems. Data loss of the whole system as a consequence
264 of an abrupt quiescent current drift after loss of one sensor connection also needs to be considered.
265 24*) For complex sensor clusters an extended noise limit is allowed and must be specified in the corresponding
266 Substandard. Corner frequencies $f_{C,1}$ and $f_{C,2}$ are 3dB frequencies of 1st order filter characteristics. There is no
267 noise limit for frequencies lower than $f_{C,1}$ or higher than $f_{C,2}$.

4.7.2 Absolute Maximum Ratings

Table 15: Parameter specification of absolute maximum ratings

N°	Parameter	Symbol	Conditions/Remark	Min	Typ	Max	Unit
1*	Reverse polarity protection	I_{rev}	Standard; $t < 80ms$	-105			mA
2*			Extended; $t < 50ms$	-130			mA

268 1,2*) ECU to switch off the supply voltage after max. 80ms and 50ms respectively.

4.7.3 Configuration Modes & Options

269 In general, system parameters are grouped into two main configuration modes: “Common Mode” and “Low
270 Power Mode”. These constitute a basic preselection of physical layer parameters. The choice of physical layer
271 parameters compiled for common mode is supporting, due to legacy reasons, parameters from PSI5 Standards
272 V1.3 as well as new parameters introduced since V2.0. The limitation of the physical layer parameters
273 compiled for low power mode is done with motivation to lower the power supply needs of the interface for
274 future applications.

275 In addition, from PSI5 Technical Specification V2.0 onwards, several physical layer options have been defined
276 in order to satisfy extended application requirements. The affected parameters are:

- 277 • Supply voltage V_{CE}, V_{SS}
- 278 • Sync Signal Sustain Voltage V_{t2} , sensor trigger threshold V_{TRIG}
- 279 • Sink Current ΔI_S
- 280 • Signal noise limit ΔI_{LOW}
- 281 • Interface quiescent current I_{LOW} @ ECU
- 282 • Internal ECU Resistance R_E

283 Please be aware, that not all options can be combined and their selection must be made for specific
 284 applications as described in the respective Substandard. Because of this it is in responsibility of the system
 285 vendor to evaluate what features are necessary to fulfill the system requirements and assure that the
 286 combination of features is compatible.

Table 16: Parameter compilation for Common Mode and Low Power Mode operation

N°	Parameter	Symbol	Option	Remark	Common Mode	Low Power Mode
1	Supply Voltage @ ECU / Sensor	V_{CE}, V_{SS}	Standard Voltage		X	X
2			Low Voltage		X ¹⁾	X
3			Increased Voltage ²⁾	Only relevant for V_{CE}	X	X
4	Sync signal sustain voltage	V_{T2}	Reduced sync pulse	Affects related parameters V_{TRIG} , V_{EMC} see Table 22	X	X
5			Standard sync pulse		X	-
6	Sink current	ΔI_s	Common Mode		X	-
7			Low Power Mode		-	X
8	Signal noise limit	$\Delta(I_{S,LOW})$	Standard noise limit		X	-
9			Extended noise limit	For complex sensor cluster only	X	-
10			Reduced noise limit		-	X
11	Interface quiescent current tracking @ ECU	$I_{E,LOW}$	Standard	Affects related parameters $I_{E,LIMIT}$, $I_{E,LIMIT,dyn}$	X	X
12			Extended		X	X
13	Internal ECU resistance	R_E	Standard		X	-
14			Advanced		X	X

287 1) Low supply voltage can conflict with the maximum sink current with respect to full functionality within the scope
 288 of all given PSI5 parameters. For low voltage operation additional reduction of interface quiescent current is
 289 recommended.

290 2) Increased Supply Voltage @ ECU can optionally be applied to overcome additional voltage drops in Universal
 291 Bus and Daisy Chain Bus applications.

292 Voltage options:

- 293 • Standard voltage operation values of V_{CE} , $V_{CE,BASE}$, V_{SS} , $V_{SS,BASE}$ in this specification have been
 294 determined by simulation under Worst Case values of current and wire parasitic elements.

Technical Specification	PSI5 Peripheral Sensor Interface – Base Standard	30 / 65
		V2.3

- 295 • Operation with increased supply voltage @ ECU can optionally be applied to overcome additional
296 voltage drops in Universal Bus and Daisy Chain Bus applications in combination with standard supply
297 voltage @ Sensor.
- 298 • In particular in low voltage operation, functionality has to be ensured by system designer. Constraints on
299 full bus mode operability are possible in single cases and depend upon parameter dimensioning of the
300 system in total. For Common Mode low supply voltage can conflict with the maximum sink current with
301 respect to full functionality within the scope of all given PSI5 parameters.
- 302 • In addition to supply voltage options a reduced sync pulse option can be used to ease the requirement
303 on the sync pulse generation. The reduced sync pulse scheme is valid for new applications compliant
304 with PSI5 Technical Specification V2.0 onwards and defined for both common and low power mode. The
305 standard sync pulse voltage is in compliance with former PSI5 versions, still valid and defined for the
306 common mode only.

307 Current options:

- 308 • For low power mode an option for a lower sink current ΔI_S is available, which will affect the functionality
309 and robustness of system implementations within the full range of all given PSI5 parameters. It follows
310 that for low power operation simple configurations and shorter cable lengths (e.g. in point to point
311 configuration) are beneficial, yet a specific system validation is required. For low voltage operation
312 additional reduction of quiescent current is recommended
- 313 • Extended noise limit $\Delta(I_{S,LOW})$ applies to complex sensor clusters in single sensor configuration
- 314 • Reduced noise limit $\Delta(I_{S,LOW})$ is valid for standard and extended current.
- 315 • Extended current range is intended for applications with higher current consumption e.g in bus or sensor
316 cluster configurations.

317 Other options:

- 318 • The advanced option for R_E is to be used with advanced systems capable of using low power mode.
319 Other systems can use the standard option.

4.8 Dynamic Bus Behavior

4.8.1 Test Network Parameters

320 For compliance testing purposes of either sensor or ECU as DUT a dedicated a set of network parameters for
321 the remaining system is given in the section below.

4.8.1.1 Sensor Damping Behavior

322 The sensor damping behavior is described by a complex impedance Z_S containing an equivalent resistance
323 R_S and an equivalent capacitance C_S connected in serial, as shown in Figure 23. It should be noted that both
324 C_S and R_S have to stay within the limits given at the Sections 4.3 and 4.4 for the specified frequency range.

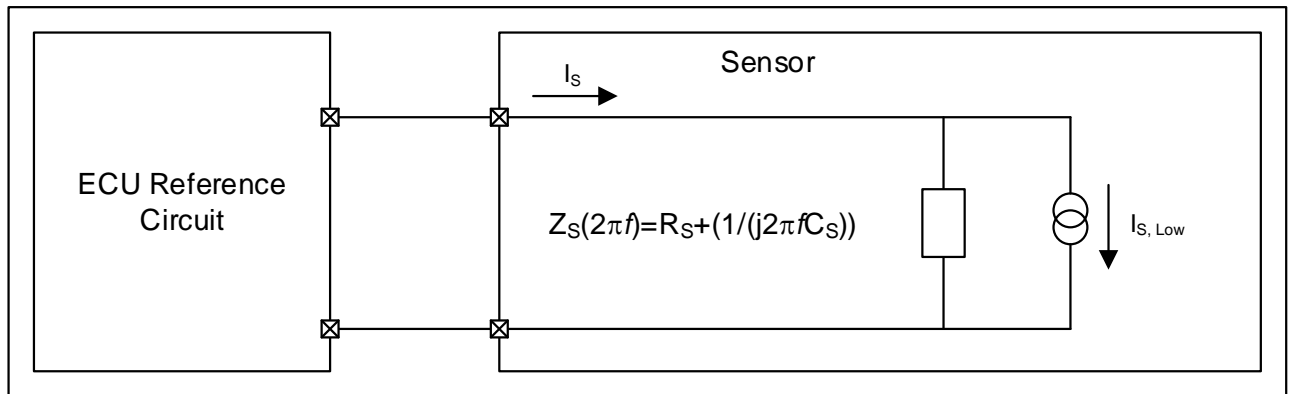

Figure 23: Reference circuit for sensor damping behavior

4.8.1.2 Sensor Testing

325 All indications in this section are valid for all configurations with N_S up to three sensors and for a data
326 transmission rate of 125kbps.

Table 17: Reference network for sensor testing

N°	Parameter	Symbol/Remark	Min	Nom	Max	Unit
1*	Supply voltage	V_E			11	V
2*	ECU internal resistance	R_{E1}	2.5		10	Ω
3*	ECU resistance at output pin (damping resistor)	R_{E2}		2.5		Ω
4*	ECU internal capacitance	C_{E1}	13		33	nF
5*	ECU capacitance at output pin	C_{E2}		2.2		nF
6*	Bus load capacitance @ DUT (ECU & other sensors)	$C_L = C_{E2} + (N_S - 1)C_S$	2.2		50	nF

327 1*) Minimum supply voltage has to be adjusted to meet $V_{SS, min}$.

328 2*) Maximum internal ECU resistance R_{E1} has to be adjusted to meet the allowed R_E maximum values.

329 2-3*) $R_{E1} + R_{E2} = R_E$, shown in Section 4.3 and 4.4.

330 4-5*) $C_{E1} + C_{E2} = C_E$, shown in Section 4.3 and 4.4.

331 6*) Wire capacitance C_W can be omitted.

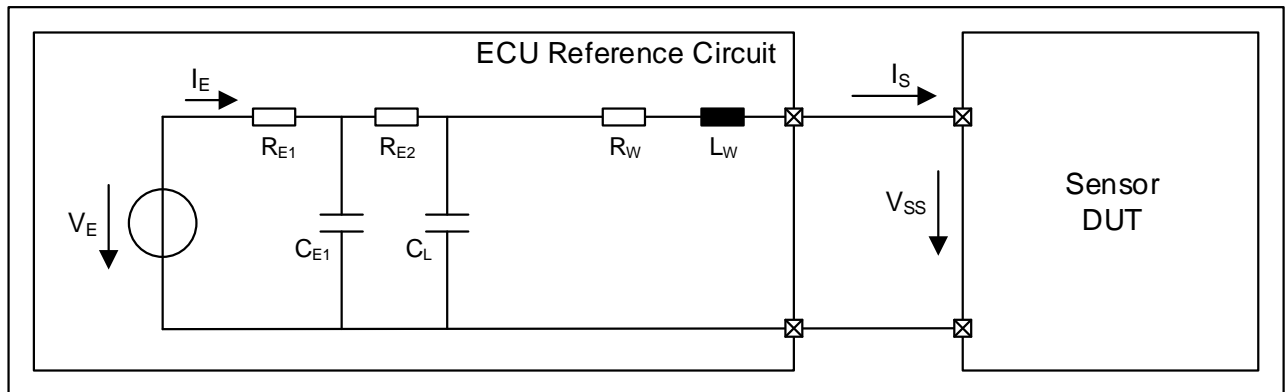

Figure 24: Reference circuit for sensor testing

4.8.1.3 ECU Testing

332 All indications in this section are valid for all configurations with N_s up to three sensors and for a data
 333 transmission rate of 125kbps. All other sensor parameters follow the values given at Sections 4.3 and 4.4.

Table 18: Reference network for ECU testing

N°	Parameter	Symbol/Remark	Min	Nom	Max	Unit
6*	Bus load capacitance @ DUT (all sensors)	$C_L = (N_s)C_s$	2.2		50	nF

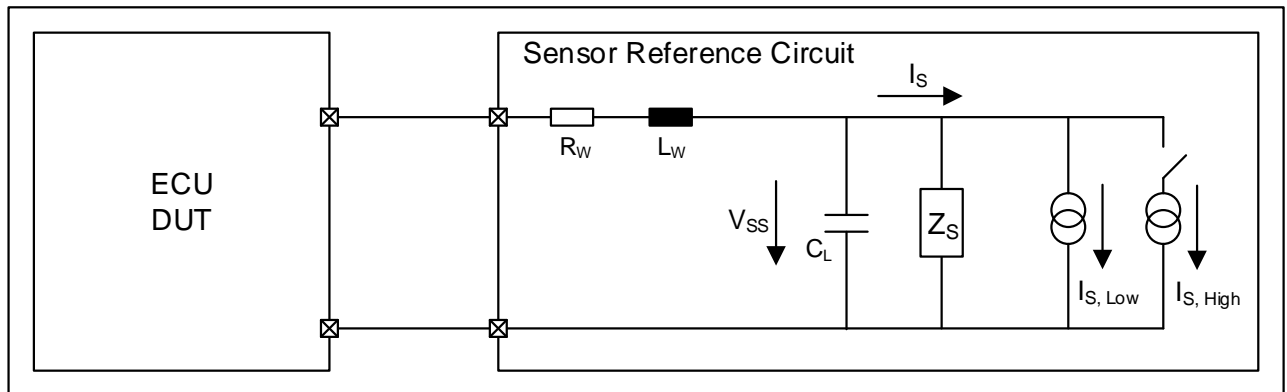

Figure 25: Reference circuit for ECU testing

4.8.2 Requirements for Dynamic Sensor Testing

334 In order to verify the proper sensor behavior the dynamic performance needs to be tested. To do so two test
 335 scenarios are given below: A and B. These represent the inductive (A) and capacitive (B) worst case coupling
 336 on a bus respectively. The fulfillment of the parameters below are a necessary requirement for compliance of
 337 the sensor device to PSI5 Specification. Nevertheless it is mandatory to verify the proper communication within
 338 a bus configuration in the final application. In Figure 26 and Table 19 all relevant test conditions are given.

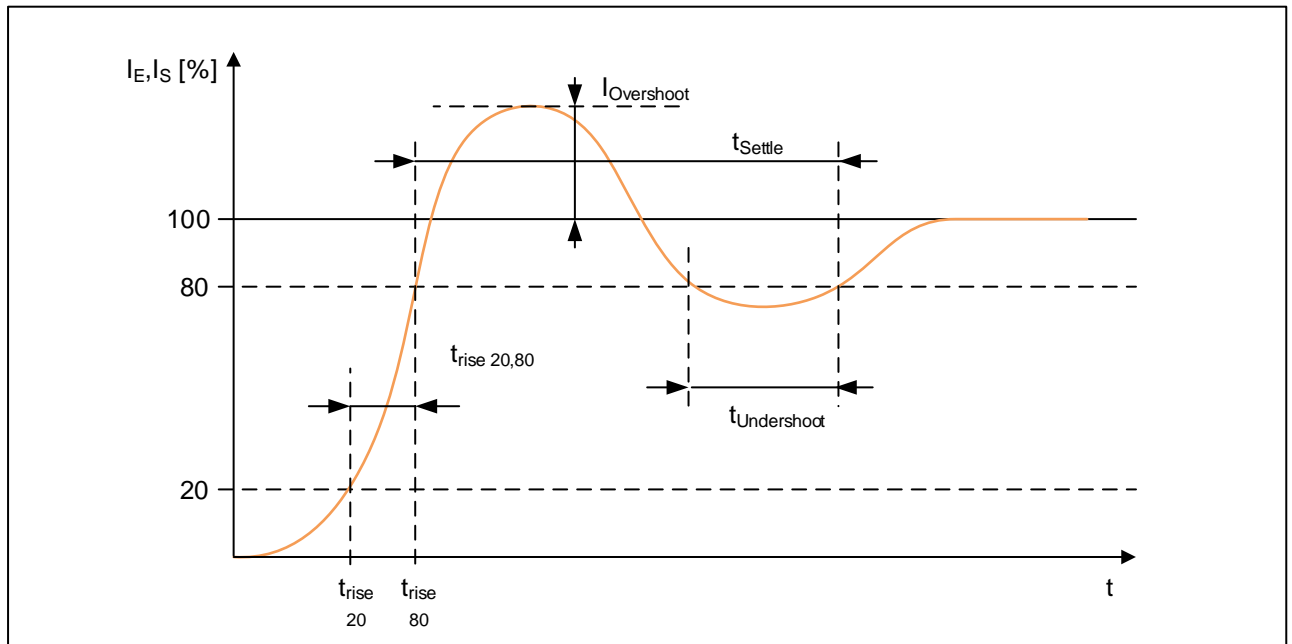

Figure 26: Dynamic behavior of supply / communication current

Table 19: Parameter specification for sensor reference test

N°	Parameter	Symbol/Remark	Min	Nom	Max	Unit
A*	Worst case overshoot @ ECU					
	Test condition: $R_{E1} = 2.5\Omega$; C_E variable between 13nF and 33nF; $C_L = 2.2nF$; $R_W = 0.1\Omega$; $L_W = 8.7\mu H$					
A1	Sending current over- / undershoot @ ECU	$I_{Overshoot, rise}$ & $I_{Undershoot, fall}$ (I_S)			50	%
A2	Time for under- / overshoot @ ECU	$t_{Undershoot, rise}$ & $t_{Overshoot, fall}$ (I_E)			0.52	μs
A3	Settling time @ ECU	t_{Settle} (I_E)			1.72	μs
A4*	Voltage ripple @ Sensor	referenced to $V_{SS, base}$	-0.8		+0.8	V
B*	Worst case timing @ ECU					
	Test condition: $R_{E1} = 10\Omega$ (7 Ω); $C_E = 33nF$; $C_L = 50nF$; $R_{wire} = 2.5\Omega$; $L_{wire} = 0\mu H$					
B1	Sending current rise/fall time @ ECU	$t_{rise 20, 80}$ & $t_{fall 80, 20}$ (I_E)			1.8	μs

- 339 A*) The sensor has to fulfill reference Test A for every value of the capacitance C_E .
- 340 A4*) Parameter is only valid for systems in common mode operation with a minimum V_{CE} of 5.5V ($V_{SS}=5.0V$). For low
- 341 voltage operation the maximum allowed voltage ripple can differ, but has to be validated on system level.
- 342 B*) Maximum internal ECU resistance R_{E1} has to be adjusted to meet the allowed R_E maximum values.

4.8.3 Requirements for Dynamic ECU Testing

343 In order to verify the proper ECU behavior the dynamic performance needs to be tested. To do so two test

344 scenarios are given below: A and B. These represent the inductive (A) and capacitive (B) worst case coupling

345 on a bus respectively. The fulfillment of the parameters below are a necessary requirement for compliance of

Technical Specification	PSI5 Peripheral Sensor Interface – Base Standard	34 / 65
		V2.3

346 the ECU to the PSI5 Specification. Nevertheless it is mandatory to verify the proper communication within a
347 bus configuration in the final application.

Table 20: Parameter specification for ECU reference test

N°	Parameter	Symbol/Remark	Min	Nom	Max	Unit
A*	Worst case overshoot @ ECU					
	Test condition: $R_{E1} = 2.5\Omega$; $C_L = 2.2nF$; $R_W = 0.1\Omega$; $L_W = 8.7\mu H$; C_S variable between 9nF and 24nF @10 ...200KHz and between 1.32nF and 24 nF @ 200KHz...2MHz;					
A1*	Supply Voltage @ ECU		$V_{CE,min}$		$V_{CE,BASE,max}$	V
B*	Worst case timing @ ECU					
	Test condition: $R_S = 10\Omega$; $C_S = 24nF$; $C_L = 50nF$; $R_{wire} = 2.5\Omega$; $L_{wire} = 0\mu H$;					
B1*	Supply Voltage @ ECU		$V_{CE,min}$		$V_{CE,BASE,max}$	V

348 A*) The sensor has to fulfill reference Test A for every value of the capacitance C_S .

349 A1,B1*) For min max values see Table 14.

4.9 Synchronization Signal

350 Purpose of the synchronization signal is to provide a time base for all devices connected to the interface. The
351 synchronization signal is realized by a positive voltage modulation on the power supply lines. For ECU to
352 sensor communication, bits are encoded in present or missing sync pulses, respectively. Or optional by
353 generating long and short sync pulses. The sync pulses are defined as shown in Figure 27 and in the Table
354 21.

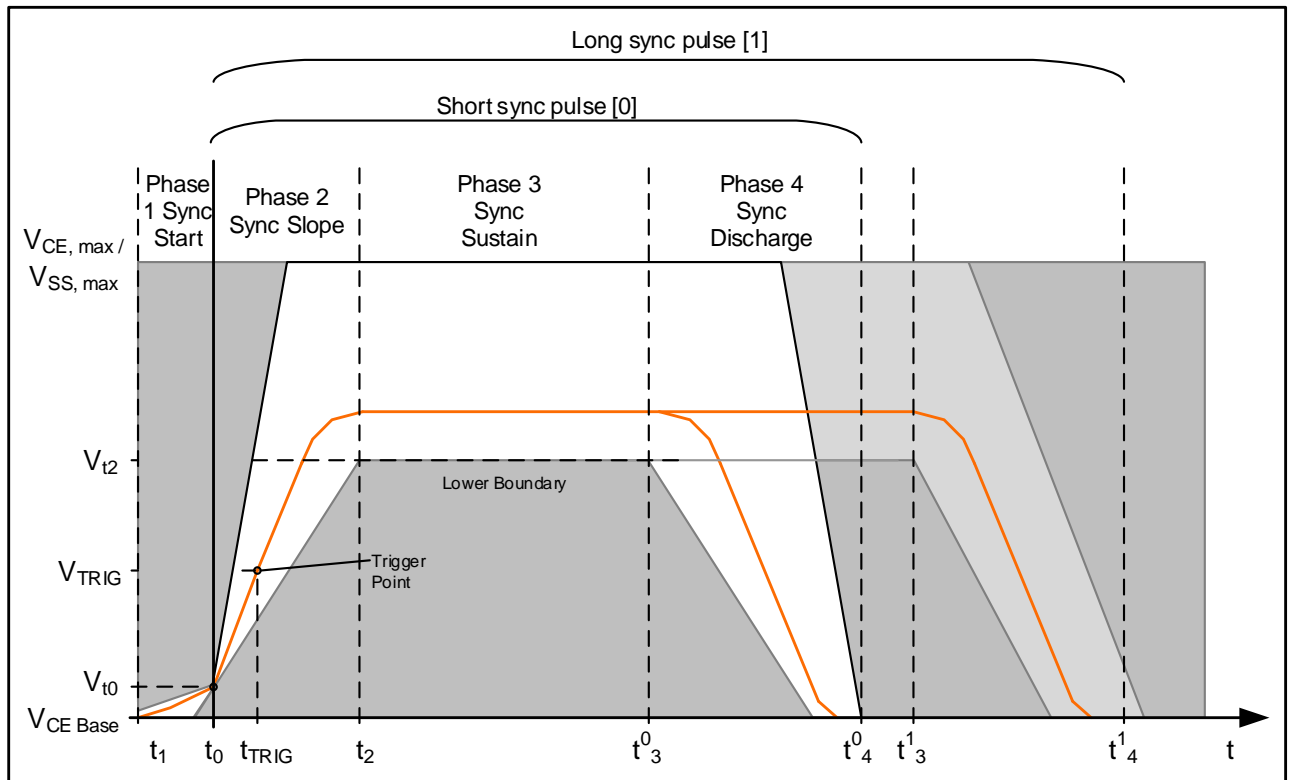

Figure 27: Shape and timing of synchronization signal at ECU

355 The synchronization signal start time t_0 is defined as a crossing of the V_{t0} value. In the “Sync Start” phase
356 before this point, a “rounding in” of the voltage starting from $V_{CE, Base}$ to V_{t0} is allowed for a maximum of t_1 .
357 During the “Sync Slope” phase, the voltage rises within given slew rates to a value between the minimum sync
358 signal voltage V_{t2} and the maximum interface voltage $V_{CE, max} / V_{SS, max}$. After maintaining between these limits
359 until a minimum of t_3^0 (t_3^1), the voltage decreases in the “Sync Discharge” phase until having reached the initial
360 $V_{CE, base}$ value until latest t_4^0 . (t_4^1)

Table 21: Parameter specification of synchronization signal

N°	Parameter	Symbol	Conditions/Remark	Min	Nom	Max	Unit
1*	Sync slope reference voltage	V_{t0}	Referenced to $V_{CE, BASE}$		(0.5)		V
2*	Sync signal sustain voltage	V_{t2}	Reduced sync pulse; Referenced to $V_{CE, BASE}$	2.5			V
3*			Standard sync pulse; Referenced to $V_{CE, BASE}$	3.5			
4*	Reference time	t_0	Reference time base		(0)		μs
5	Sync signal earliest start	t_1	Delta current less than 2mA	-3			μs
6	Sync signal sustain start	t_2	@ V_{t2}			7	μs
7*	Sync slope rising slew rate	$V_{Sync, SR, rise}$		0.43		1.5	V/ μs

Technical Specification	PSI5 Peripheral Sensor Interface – Base Standard	36 / 65
		V2.3

N°	Parameter	Symbol	Conditions/Remark	Min	Nom	Max	Unit
8	Sync slope falling slew rate	$V_{\text{Sync, SR, fall}}$		-1.5			V/ μ s
9	Sync signal sustain time	t^0_3		16			μ s
		t^1_3		43			
10*	Discharge time limit	t^0_4				35	μ s
		t^1_4				62	
11	Start of first sensor data word	$t_{\text{Slot 1 Start}}$	Tooth gap method	44			μ s
12			Pulse width method	71			μ s

361 1,4*) Theoretical value
362 2*) The reduced sync pulse scheme is valid for new applications compliant with PSI5 Technical Specification V2.0
363 onwards. However, in compliance with former PSI5 versions the standard sync pulse scheme is still valid.
364 2,3*) $V_{t2, \text{max}}$ is subject to application specific definitions and limited by absolute maximum ratings to $(V_{\text{CE, max}} - V_{\text{CE, BASE}})$.
365
366 7*) Lower limit is valid for rising slew rate V_{t0} to V_{t2}
367 10*) Common Mode: Remaining discharge current <2 mA, to be guaranteed by the ECU;
368 Low Power Mode: With Low Power Mode sink current ΔI_S a remaining discharge current <0.4 mA has to be
369 guaranteed by the ECU

370 In the sensors, the trigger is detected within the “trigger window” during the rising slope of the synchronization
371 signal at the trigger point with the trigger voltage V_{TRIG} and the trigger time t_{TRIG} .

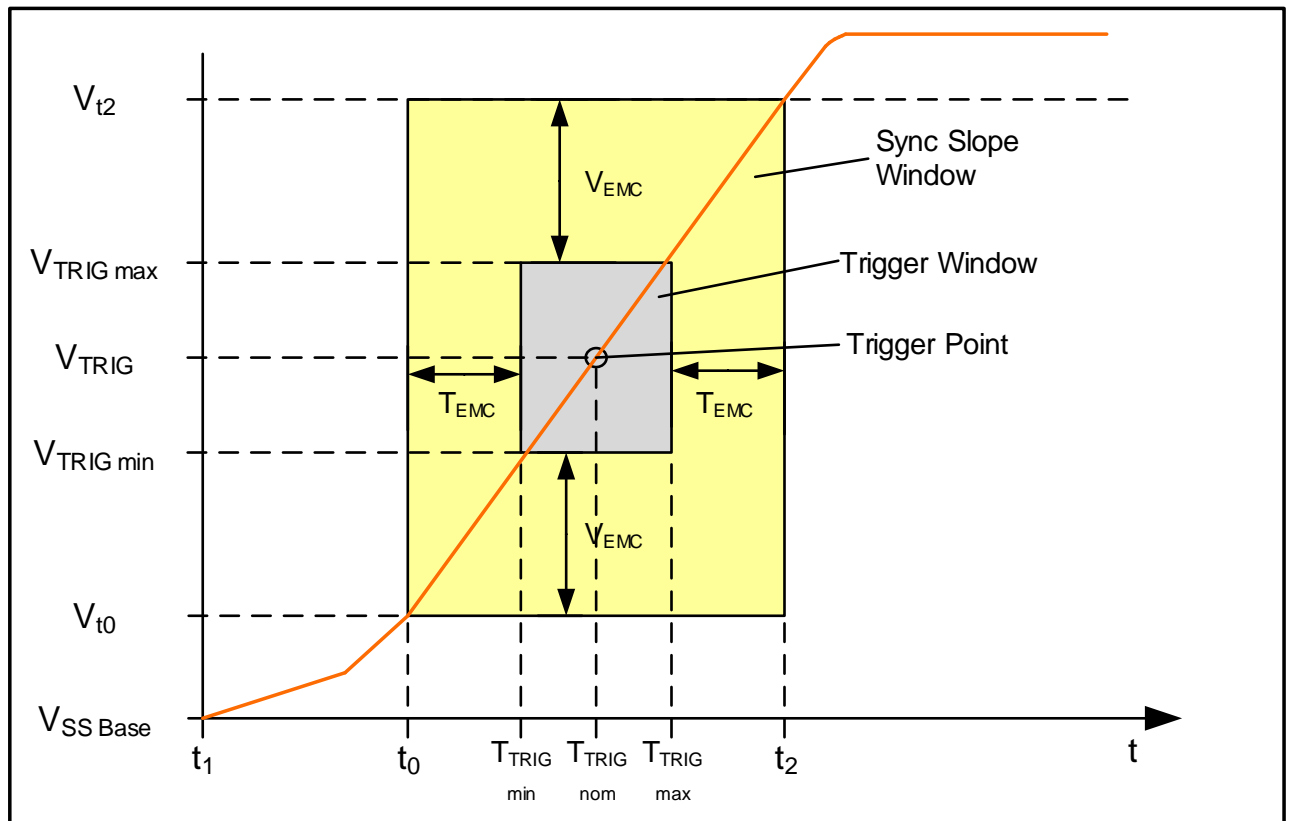

Figure 28: Synchronization signal detection in the sensor

372 In order to take into account voltage differences at different points of the interface lines, an additional safety
373 margin for the trigger detection is defined by V_{EMC} and t_{EMC} .

Table 22: Parameter specification of synchronization signal detection at the sensor

N°	Parameter	Symbol	Conditions/Remark	Min	Nom	Max	Unit
1	Margin for voltage variations of the signal on the interface line due to EMC effects	V_{EMC}	Reduced sync pulse	-0.7		+0.7	V
2			Standard sync pulse	-0.9		+0.9	
3*	Sensor trigger threshold	V_{TRIG}	Reduced sync pulse; Sensor to detect trigger	1.2	1.5	1.8	V
4*			Standard sync pulse; Sensor to detect trigger	1.4	2.0	2.6	V
5*	Nominal trigger detection time	t_{TRIG}	@ V_{TRIG} , @ Sensor Pins	(2.1)	(3.5)	(4.9)	μs
6	Variation time of the signal on the interface line due to EMC	T_{EMC}	Relative to nominal trigger window time	-2.1		+2.1	μs
7	Tolerance time of internal trigger detection delay at sensor	$T_{tol\ detect}$				3	μs

Technical Specification	PSI5 Peripheral Sensor Interface – Base Standard	38 / 65
		V2.3

N°	Parameter	Symbol	Conditions/Remark	Min	Nom	Max	Unit
8*	Trigger detection window	T_{TRIG}	$T_{TRIG} = t_{TRIG,max} + T_{tol\ detect} + T_{EMC}$ Reference for sensor timebase	0		10	μs

- 374 3-4*) Referenced to $V_{SS, BASE-}$.
- 375 5*) Referenced to a straight sync signal slope with nominal slew rate. Values in brackets are for illustration purposes
376 only
- 377 8*) Additional fixed internal delays are possible but have to be considered for the data slot time calculation

4.10 Timing Definitions for Synchronous Operation Modes

- 378 This section describes how the timing of a sensor configuration has to be calculated considering all tolerances.
- 379 Each single implementation has to assure that sensor frames and sync pulse do not overlap or conflict. For
380 different applications different timing considerations are of importance and hence, a transceiver should not rely
381 on concrete time slots but rather be individually configurable for different time slots. In general, timing
382 calculation is done for independent sensors at each slot. If more than one slot is used by the same sensor, or
383 two sensors rely on the same timing base, respectively, slot tolerances can be considered as dependent and
384 the timing can be tightened¹⁾.
- 385 State of the art operation modes and timings are specified within the effective application specific Substandard.

¹⁾ E.g. Substandard Chassis and Safety, Operation Mode PSI5-P20CRC-500/2L

4.10.1 Generic Time Slot Calculation

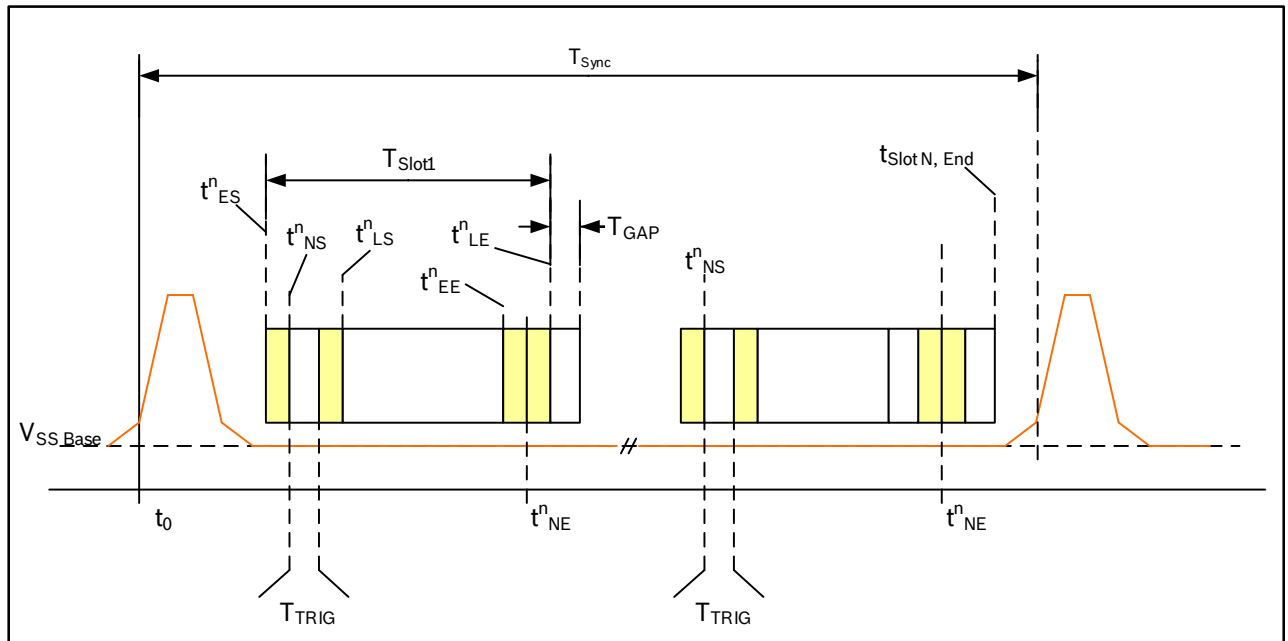

Figure 29: Timing of synchronous operation

All rights including industrial property rights and all rights of disposal such as copying and passing to third parties reserved.

- 386 t^N_{ES} : Earliest start of frame, slot n ; this is the earliest time when the transceiver or any other sensor on
- 387 the bus can expect that the frame no. n begins.
- 388 t^N_{NS} : Nominal start of frame, slot n ; this is the nominal time when the sender (sensor) transmits data
- 389 according to its own internal clock. It is the nominal time when the transceiver or any other sensor
- 390 on the bus can expect that the frame no. n begins.
- 391 $t^N_{NS, prog}$: nominal start value of frame, slot n , that is programmed to the sensor. It is derived from t^N_{NS} by
- 392 rounding up to the next discretization value.
- 393 t^N_{LS} : Latest start of frame, slot n ; this is the latest time when the transceiver or any other sensor on the
- 394 bus can expect that the frame no. n begins.
- 395 t^N_{EE} : Earliest end of frame, slot n ; this is the earliest time when the transceiver or any other sensor on
- 396 the bus can expect that the frame no. n is over.
- 397 t^N_{NE} : Nominal end of frame, slot n .
- 398 t^N_{LE} : Latest end of frame, slot n ; this is the latest time when the transceiver or any other sensor on the
- 399 bus can expect that the frame no. n is over.
- 400 T_{GAP} : Minimum gap time which must be guaranteed between two frames (see Table 13)
- 401 T_{TRIG} : Trigger detection window to detect the sync pulse = $t_{TRIG, max} + T_{tol\ detect} + T_{EMC}$ (see Table 22)
- 402 T_{Sync} : Duration of sync period e.g. for 1% transceiver clock tolerance: $T_{Sync, min} = T_{Sync} * 0.99$; $T_{Sync, max} =$
- 403 $T_{Sync} * 1.01$
- 404 $t_{Slot 1 Start}$: Earliest Start of first sensor data word (see Table 22)
- 405 T_{BIT} : Nominal time for a single bit (see Table 13)
- 406 t_1 : Sync signal earliest start (see Table 21)
- 407 M^n : No. of bits including start, data and parity or crc bits for frame, slot n .
- 408 N : No. of time slots within one sync cycle

Technical Specification	PSI5 Peripheral Sensor Interface – Base Standard	40 / 65
		V2.3

409 CTⁿ: Clock tolerance of the transmitter (sensor) sending the frame no. n.

410 For n=1

411 $t_{ES}^1 = t_{Slot\ 1\ Start} + T_{TRIG, min}$

412 $t_{NS}^{1*2)} \geq t_{Slot\ 1\ Start} / (1 - CT^1)$

413 $t_{LS}^1 \geq t_{NS, prog}^1 * (1 + CT^1) + T_{TRIG, max}$

414 $t_{EE}^1 \geq t_{ES}^1 + M^1 * T_{BIT} * (1 - CT^1)$

415 $t_{LE}^1 : \geq t_{LS}^1 + M^1 * T_{BIT} * (1 + CT^1)$

416 For n=2...N

417 $t_{ES}^n \geq (t_{LE}^{n-1} + T_{GAP}) + T_{TRIG, min}$

418 $t_{NS}^{n*}) \geq (t_{LE}^{n-1} + T_{GAP}) / (1 - CT^n)$

419 $t_{LS}^n \geq t_{NS, prog}^n * (1 + CT^n) + T_{TRIG, max}$

420 $t_{EE}^n \geq t_{ES}^n + M^n * T_{BIT} * (1 - CT^n)$

421 $t_{LE}^n \geq t_{LS}^n + M^n * T_{BIT} * (1 + CT^n)$

422 The last frame must end before the next sync pulse starts. For secure data reception a final T_{GAP} should be
423 considered³⁾:

424 $t_{Slot\ N, End} = t_{LE}^N (+ T_{GAP}) < T_{Sync, min} + t_1$

425 Note:

- 426 • “≥” is used since the final frame timing should be equalized in order to cover the whole sync period with
427 maximum margins.
- 428 • Transceiver clock tolerance determines effective sync pulse duration. A clock tolerance of 1% is
429 assumed. (see also T_{SYNC})
- 430 • A discretization of the calculated timings of nominal 0.5us is proposed

431 Please refer to each Substandard for details on timing specification and typical operation modes.

²⁾ The nominal trigger detection tolerance is neglected for calculation of tⁿ_{NS} since the nominal start time typically is used for sensor programming where detection tolerances do not apply. For the same reason it is recommended to round up tⁿ_{NS} to 0.5µs and use the rounded value (tⁿ_{NS, prog}) for the calculation of the latest start time tⁿ_{LS}

³⁾ Exceptional definitions omitting final T_{GAP} are possible.

4.11 Sensor Power-on Characteristics

432 To ensure a proper startup of the system, a maximum startup time t_{SET1} is specified. During this time, the ECU
 433 must provide a minimum current to load capacitances in sensors and wires. After this, the sensor must sink to
 434 quiescent current within the specified tolerance band.
 435 During power on the ECU may reduce the output voltage to limit the current. However, this situation must be
 436 avoided in case of the daisy chain bus. Therefore, in a Daisy Chain Bus the sensor architecture must ensure
 437 that the overall bus current stays below $I_{LIMIT, dyn.}$

4.11.1 Sensor Bus Configuration

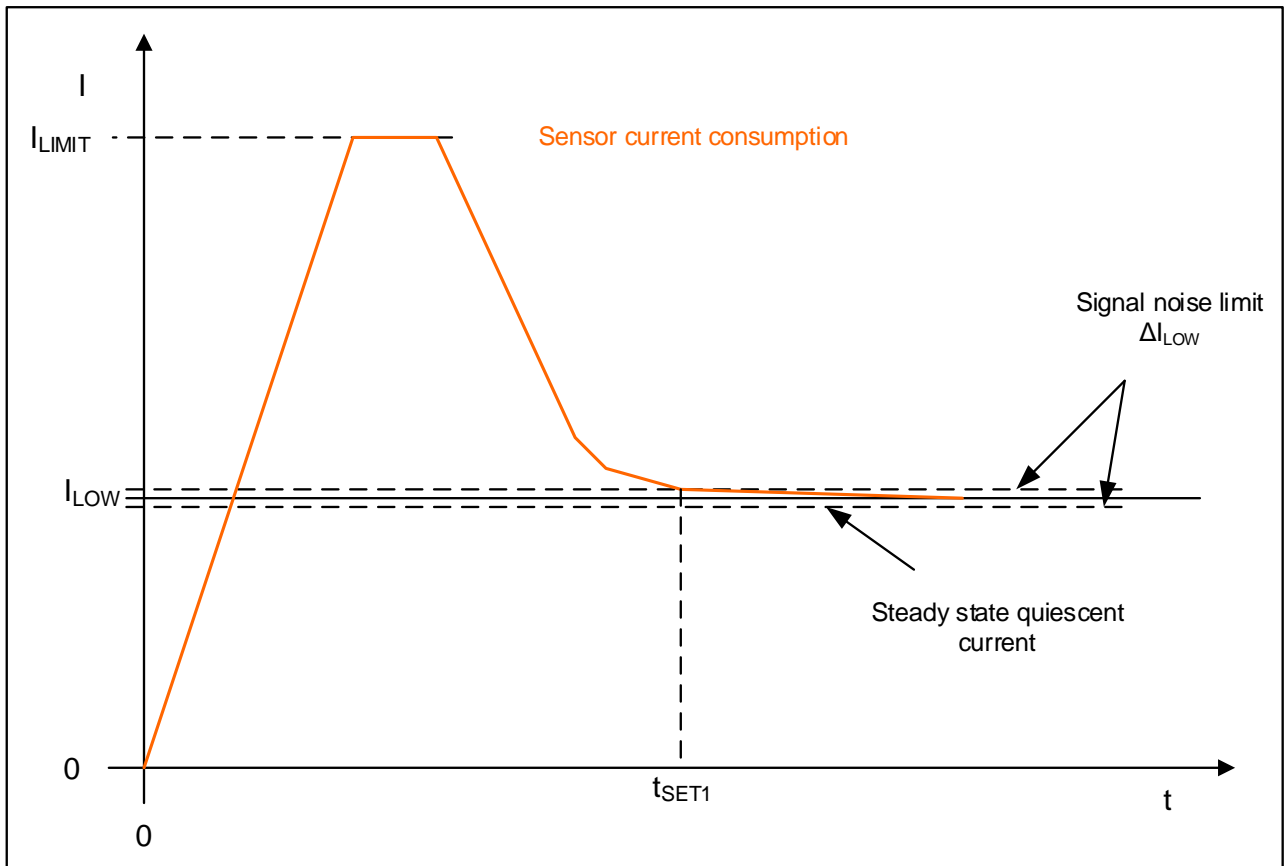

Figure 30: Current consumption during startup for sensor bus configuration

Table 23: Settling time specification for sensor bus configuration

N°	Parameter	Symbol	Conditions/Remark	Min	Typ	Max	Unit
1*	Settling time for quiescent current I_{LOW}	t_{SET1}	inrush current limitation			5.0	ms
2*			Daisy Chain Bus			10.0	ms

438 1*) Final value settles to I_{LOW} with the defined signal noise limits ΔI_{LOW} (see Table 14).
 439 2*) Mandatory settling time for quiescent current in Daisy Chain Bus. The Bus does not sink a current over $I_{LIMIT, dyn.}$
 440 at any time.

4.11.2 Extended Settling Time for Single Sensor Configuration

441 For certain sensors an extended stabilization time t_{SET2} is defined, where the current may fluctuate within the
 442 specified tolerance band for I_{LOW} before it reaches its steady state value (i.e. fluctuations between I_{LOW_min} and
 443 I_{LOW_max} are allowed). The application of such sensors is limited to single sensor configuration, since this
 444 behavior after an internal restart of one sensor in a bus configuration might disturb communication on the bus.

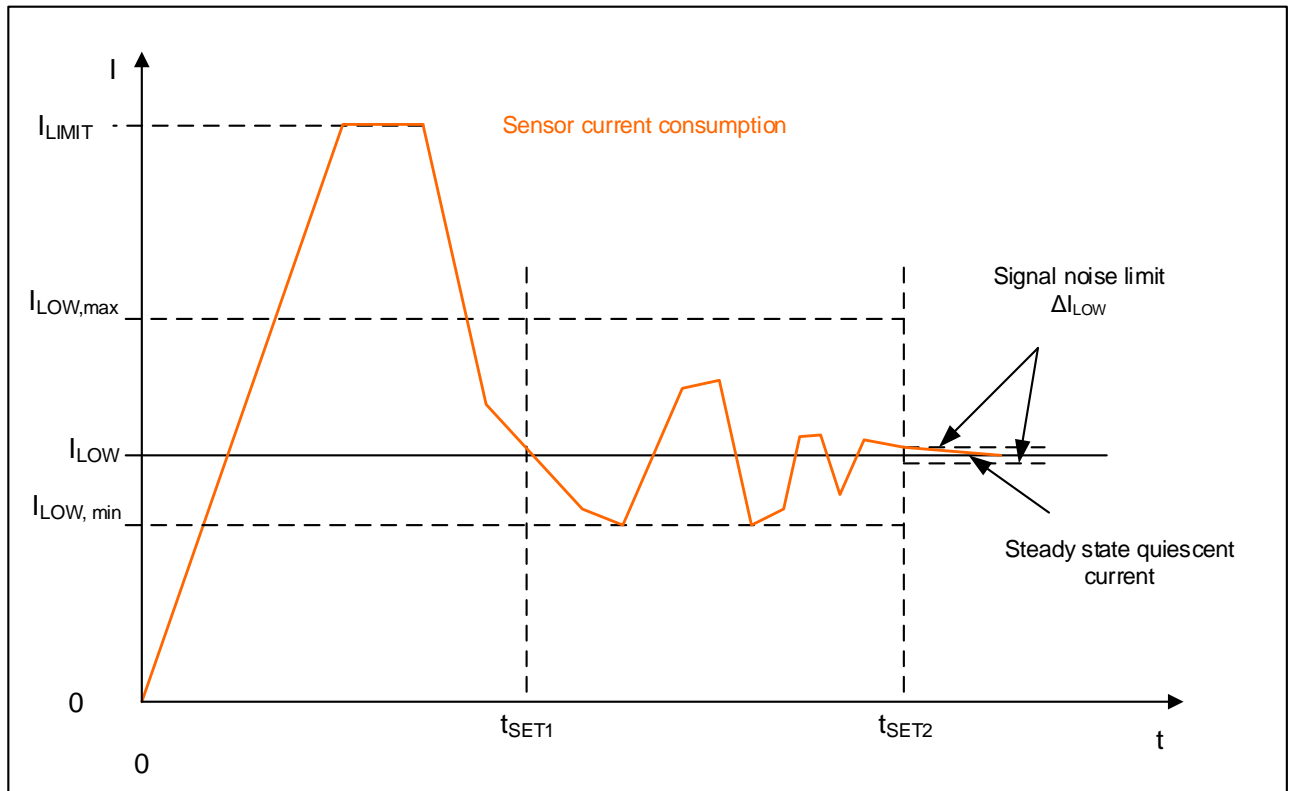

Figure 31: Current consumption during start up for certain single sensor configurations

Table 24: Extended settling time specification for single sensor configuration

N°	Parameter	Symbol	Conditions/Remark	Min	Typ	Max	Unit
1*	Settling time for quiescent current I_{LOW}	t_{SET1}	inrush current limitation between $I_{LOW,min}$ and $I_{LOW,max}$			5.0	ms
2*		t_{SET2}	Extended stabilization time			*	ms

445 1,2*) The time elapsed between $t=0$ and $t=t_{SET2}$, max cannot exceed the minimum duration of Initialization Phase I
 446 (<50ms for airbag and chassis and safety; <10ms for power train; preferably limited to $\frac{1}{2}$ of the minimum time
 447 limit of Initialization Phase I); the final value is given in the application specific Substandard;

448 2*) Fluctuations between $I_{LOW,min}$ and $I_{LOW,max}$ are allowed; the receiver might indicate communication error for
 449 $t < t_{SET2}$. Final value settles to I_{LOW} with the defined signal noise limits ΔI_{LOW} (see Table 14).

4.12 Undervoltage Reset and Microcut Rejection

450 The application-specific Substandards specify, whether an internal reset of the sensor is mandatory or optional.
 451 In those cases where mandatory, undervoltage reset thresholds are also specified in detail within the
 452 respective Substandard.
 453 If specified, the sensor must perform an internal reset if the supply voltage drops below a certain threshold for
 454 a specified time. By applying such a voltage drop, the ECU is able to initiate a safe reset of all attached sensors.
 455 Microcuts might be caused by lose wires or connectors. Microcuts within the specified limits shall not lead to
 456 a malfunction or degraded performance of the sensor.

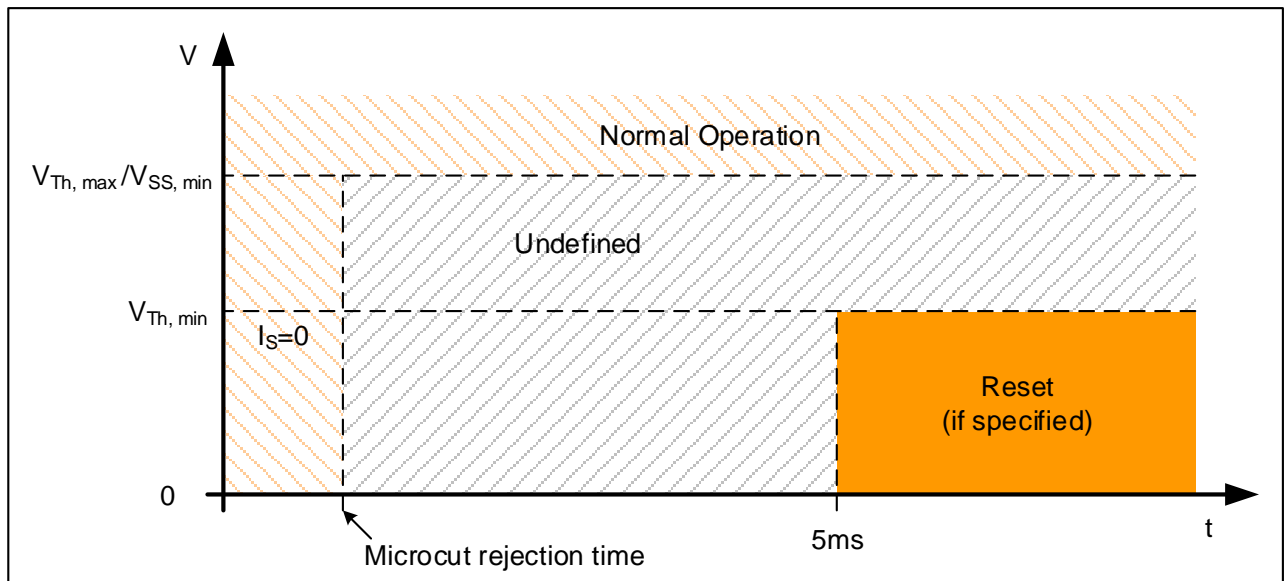

Figure 32: Undervoltage reset behavior

Table 25: Parameter specification for undervoltage reset and microcut rejection

N°	Parameter	Symbol	Conditions/Remark	Min	Typ	Max	Unit
1	Undervoltage reset threshold	V_{Th}	Standard Voltage; $V_{Th, min} = \text{must reset};$ $V_{Th, max} = V_{SS, min}$	(*)		5	V
2			Low Voltage; $V_{Th, min} = \text{must reset};$ $V_{Th, max} = V_{SS, min}$	(*)		4	V
3	Time below threshold for the sensor to initiate a reset	t_{Th}		(*)		5	ms
4	Microcut rejection time (no reset)	$I_S=0$		0.5			μs

457 (*) Defined within the application specific Substandard

458 The voltage V_{Th} is at the pins of the sensors. In case of microcuts ($I_S=0$) to the maximum duration of the
 459 microcut rejection time the sensor shall not perform a reset. If the voltage at the pins of the sensor remains

Technical Specification	PSI5	44 / 65
	Peripheral Sensor Interface – Base Standard	V2.3

460 above $V_{Th,max}$ the sensor must not perform a reset. If the voltage at the pins of the sensor falls below $V_{Th,min}$
461 for more than 5ms the sensor has to perform a reset, if a reset is specified in the application specific
462 Substandard.
463 Different definitions may apply for Universal Bus and Daisy Chain Bus.

5 Application Layer

464 Specific application layer implementations are defined in the application Substandards or in individual product
 465 specifications. In order to enable global interoperability between PSI5 compatible components and to avoid
 466 potential system malfunction due to erroneous recognition of components, some global definitions about data
 467 range, sensor initialization and bidirectional communication are made in this section.

5.1 Data Range

468 PSI5 data messages, transmitted in data region A, are divided into three separate ranges: a data range for the
 469 sensor output signal, a range for status and error messages and a range for initialization data.

470 For 10 bit sensors, the decimal values –480 to +480 are used for the sensor output signal. The range –512 to
 471 –481 is reserved for the block and data ID's and can be used for transmitting initialization data during startup
 472 of the sensor (see Chapter 5.2). The range from +481 to +511 is used for status and error messages.

Table 26: Data range (10 Bit)

value		Signification	Range	
Dec	Hex			
+511	0x1FF	Reserved (ECU internal use) ¹⁾	Status & Error Messages	2
:	:	Reserved (ECU internal use) ¹⁾		
+504	0x1F8	Reserved (ECU internal use) ¹⁾		
+503	0x1F7	Reserved (Sensor use) ²⁾		
+502	0x1F6	Reserved (Sensor use) ²⁾		
+501	0x1F5	Reserved (Sensor use) ²⁾		
+500	0x1F4	"Sensor Defect"		
+499	0x1F3	Reserved (ECU internal use) ¹⁾		
:	:	Reserved (ECU internal use) ¹⁾		
+496	0x1F0	Reserved (ECU internal use) ¹⁾		
+495	0x1EF	Reserved (Sensor use) ²⁾		
:	:	Reserved (Sensor use) ²⁾		
+489	0x1E9	"Sensor in Service Mode"		
+488	0x1E8	"Sensor Busy"		
+487	0x1E7	"Sensor Ready"		
+486	0x1E6	"Sensor Ready but Unlocked"		
+485	0x1E5	Reserved (Sensor use) ²⁾		
+484	0x1E4	Reserved (Sensor use) ²⁾		
+483	0x1E3	Reserved (Sensor use) ²⁾		
+482	0x1E2	Bidirectional Communication: RC "Error"		
+481	0x1E1	Bidirectional Communication: RC "O.K."		

value		Signification	Range	
Dec	Hex			
+480	0x1E0	Maximum Sensor Data value	Sensor Output Signal	1
:	:	:		
0	0x000			
:	:	:		
-480	0x220	Minimum Sensor Data value	Data for Initialization	3
-481	0x21F	Status Data 1111		
:	:	:		
-496	0x210	Status Data 0000		
-497	0x20F	Block ID 16	Block ID's	
:	:	:		
-512	0x200	Block ID 1		

- 473 1) Usage for ECU internal purpose possible (e.g. "No Data", "Manchester Error" etc.)
- 474 2) Reserved for application specific definitions. Detailed description is given within the application specific
- 475 Substandard.

5.1.1 Scaling of Sensor Output

476 For sensors with a data word length of more than 10 bit, the data range scales as described in Chapter 3.1.3.

477 In this case status and initialization data words of range 2 and 3 are filled up with a value to be defined in the

478 application specific substandard.

Mapping of Status & Initialization Data																
16 Bit Data Word	D15	D14	D13	D12	D11	D10	D9	D8	D7	D6	D5	D4	D3	D2	D1	D0
	1	0	0	0	0	0	1	1	1	1	X	X	X	X	X	X
10 Bit Data Word	D9	D8	D7	D6	D5	D4	D3	D2	D1	D0						
	1	0	0	0	0	0	1	1	1	1						
Example „Block ID 16“ 0x20F	„2“			„0“			„F“									

Figure 33: Mapping of status and initialization data into a data word

5.2 Sensor Initialization / Identification

479 Sensor Initialization data is sent after each power on or reset. Therefore two different transmission procedures

480 can be applied:

- 481 1) Data Range Initialization: Identification data is sent during an initialization procedure before any
482 effective sensor data is sent.
- 483 2) Serial Channel Messaging: For immediate access to measurement data, identification data is
484 transmitted parallel to sensor data via serial channel bits M0 and M1. The sensor immediately starts
485 with parallel transmission of measurement and sensor identification data.

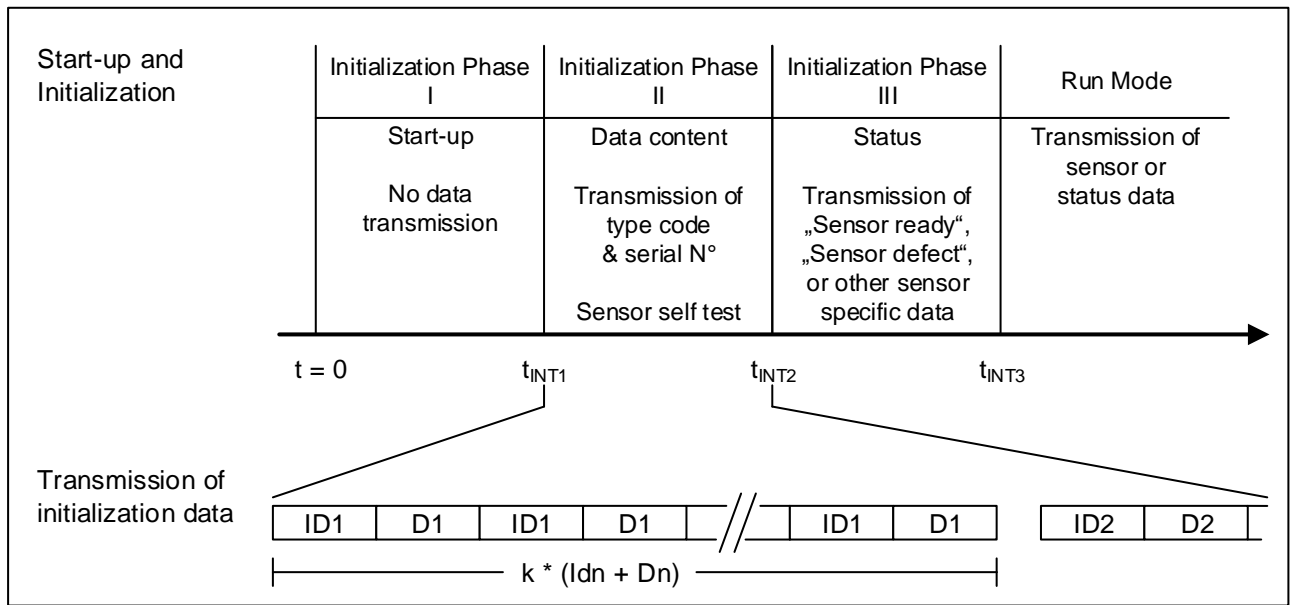

Figure 34: Sensor initialization sequence for Data Range Initialization

486 Chapter 5.2.1 defines the Data format of the Data Range Initialization procedure, further details are given in
487 the corresponding Substandards. The Serial Channel Messaging is fully defined on application level, i.e. within
488 the specific Substandard. Chapter 5.2.2 and 5.2.3 define basic regulations of the Application Layer that need
489 to be followed by both identification procedures.

5.2.1 Frame Format - Data Range Initialization

490 The initialization data is transmitted within the range of “Payload Data Region A” out of the reserved data range
491 2 and 3 in Table 26. Sensor identification data is sent via data range 3 using ID and data blocks containing
492 each 16 block identifiers and 4-bit data nibbles. Exceptions or failure modes are sent via data range 2.

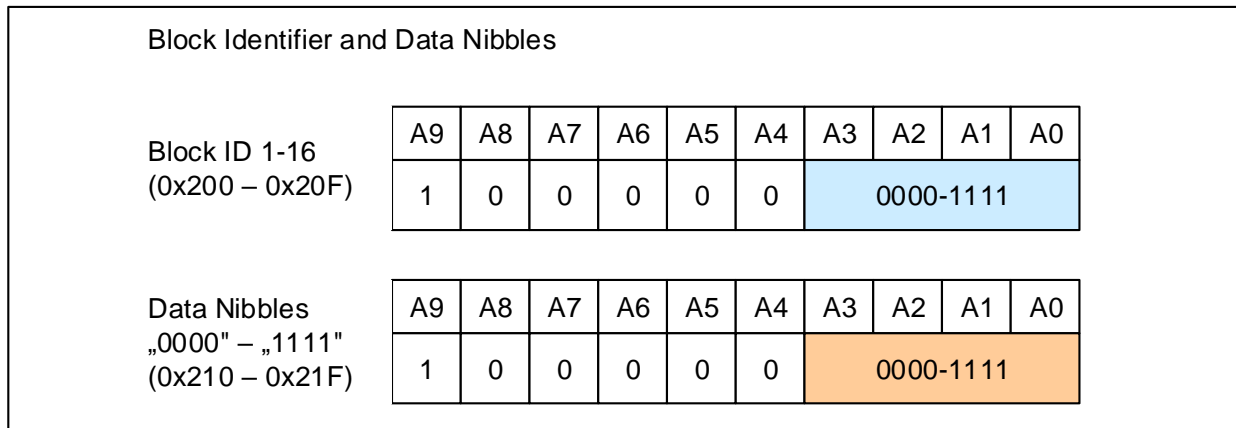

Figure 35: Block ID and data nibbles

493 ID blocks and data blocks are sent in an alternating sequence.

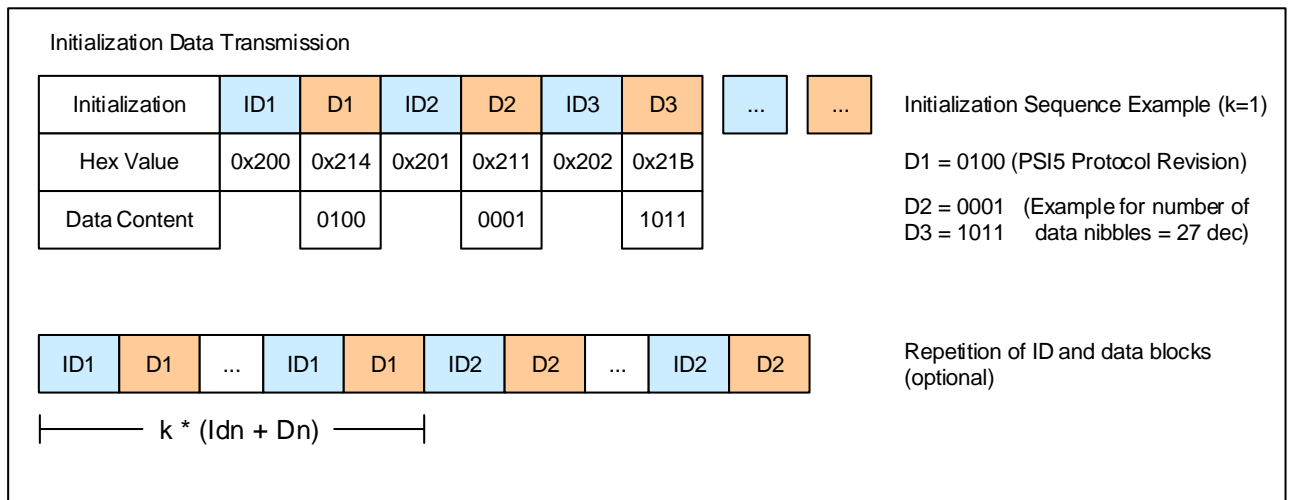

Figure 36: Startup sequence

494 If the initialization data exceeds 4x16=64 bit, data can be “paged”. The ID codes are reused for every 64 bit
495 page of data to be transmitted. Data pages are not numbered. Mapping of the information contained in different
496 data pages has to be derived from the chronology of the startup sequence. It is not mandatory to transmit
497 complete data pages.

5.2.2 Data Content - Data Range Initialization

Table 27: Mandatory definitions

	Header	Initialization		Vendor ID		Product ID			
Data field	F1	F2		F3		F4		F5	
Data nibble	D1	D2	D3	D4	D5	D6	D7	D8	D9
	PSI5 version	No. of data nibbles		Vendor ID		Sensor type		Sensor parameters	

Table 28: Initialization data content

Field	Name	Parameter definition	Value
F1 (D1)	Meta Information (See section below)	Protocol Description (D1)	
		PSI5 1.3	0100
		PSI5 2.x, Data Range Initialization	0110
F2 (D2, D3)	Initialization data length Number of data nibbles transmitted	Example: F1-F9	Example: 0010 0000
F3 (D4, D5)	Vendor ID	s. chapter 5.2.4	
F4 (D6, D7)	Sensor Type Definition of the sensor type (acceleration, pressure, temperature, torque, force, angle, etc.)	Acceleration Sensor (High g)	XXXX 0001
		Acceleration Sensor (Low g)	XXXX 0010
		Pressure Sensor (high sensitivity)*	XXXX 1000
		Pressure Sensor (low sensitivity)*	XXXX 1100
		Position Sensor (Angular)	XXXX 0110
		Position Sensor (Linear)	XXXX 0111
F5 (D8,D9)	Sensor Parameter Definition of sensor specific parameters e.g . measurement range.	other sensors	tbd
		Information depending on the corresponding sensor type	Sensor specific definition

498 *) Differentiation between low and high sensitivity/acceleration is meant to distinguish between different sensitivity
499 ranges for sensors on the same bus.

500 Further details of initialization data structure and contents are given in the respective Substandards. In addition
501 to the mandatory definitions of this document and the Substandards extended sensor parameters can be
502 appended if needed (F2 to be changed accordingly).

5.2.3 Meta Information

503 In cases where sensors from different application fields are connected to one bus system (e.g. powertrain and
504 chassis and safety sensors) the interoperability of the different protocols must be guaranteed. For that reason
505 an optional “meta information” header is transmitted minimum once at the very beginning of the identification
506 phase indicating the PSI5 version and the method used for identification data transmission. Irrespective of the
507 applied identification procedure the header data field is sent in status data format (10-Bit value out of data
508 range 3).

509 For systems that use the Data Range Initialization the meta header is mandatory and consists of at least one
510 identifier (ID1) and one data nibble (D1).

Technical Specification	PSI5 Peripheral Sensor Interface – Base Standard	50 / 65
		V2.3

Table 29: Meta Header

Name	Parameter definition	Value
Header	Protocol Description (D1)	
	PSI5 1.x	0100
	PSI5 2.x, Data Range Initialization	0110
	PSI5 2.x, Serial Channel Initialization	0111

5.2.4 Vendor ID

511 The Vendor ID is sent with both methods and coded as defined below.

Table 30: Vendor IDs

Name	Parameter definition	ASCII Code
Vendor ID (8 bit Sensor Manufacturer Code)	AB Elektronik	1100 0000
	AMS	1110 0000
	Analog Devices	0110 0001
	Autoliv*	0100 0001
	Bosch*	0100 0010
	Continental*	0100 0011
	Denso	0100 0100
	ELMOS	0100 0101
	Hella	0100 1000
	IHR	0110 1001
	Infineon	0100 1001
	Hyundai Mobis	0100 1101
	TDK	0110 1101
	NXP	0100 0110
	OnSemi	0100 1111
	Seskion	0111 0011
	ST Microelectronics	0101 0011
TRW	0101 0100	
Other sensor manufacturers	tbd	

512 *) These vendor IDs are effective from PSI5 Technical Specification V2.0 onwards and mandatory for all future
513 applications; in compliance with PSI5 V1.3 former codes are still valid. That is specifically regarding Autoliv
514 (0100 0000), Bosch (0001 0000), Continental (1000 0000), Siemens VDO (0010 0000).

Technical Specification	PSI5	51 / 65
	Peripheral Sensor Interface – Base Standard	V2.3

5.3 Bidirectional Communication

515 In the table below the allowed up- and downstream combinations are shown.

Table 31: Combination of bidirectional communication options

Upstream (Sensor response to ECU)	Downstream (ECU to Sensor)	Remark
Data range 2 & 3	Tooth Gap method note: frame format is restricted to frame 1-3 (see Chapter 5.3.1)	PSI5 1.3 compliant
Data range 2 & 3	Pulse Width method	
Serial channel	Pulse Width Method	

516 In the following basic regulations of data contents are given that need to be followed by all PSI5 applications.

5.3.1 Sensor Addresses

Table 32: Sensor addresses

Mnemonic	SAdr			Signification
	A2	A1	A0	
S0	0	0	0	Address of an unprogrammed sensor (Daisy Chain)
S1	0	0	1	Sensor 1 (Slot #1)
S2	0	1	0	Sensor 2 (Slot #2)
S3	0	1	1	Sensor 3 (Slot #3)
S4	1	0	0	Sensor 4 (Slot #4)
S5	1	0	1	Sensor 5 (Slot #5)
S6	1	1	0	Sensor 6 (Slot #6)
BCast	1	1	1	Broadcast address for all sensors

5.3.2 Function Codes and Responses for Bidirectional Communication – Frame 1 to 3

Table 33: Function codes and responses for bidirectional communication – Frame 1 to 3

Mnemonic	SAdr			FC			Signification	Response	
	A2	A1	A0	F2	F1	F0		o.K.	Error
Set Sensor Address & Run Command (Short Data Frame)									
Condition: SAdr = "000" or SAdr = "111"									
SetAdr	0	0	0	Address to be programmed			Set Sensor Address & Close Bus Switch (The "FC" field contains the sensor address)	RC: "o.K."	RC: "Error"
				A2	A1	A0		RD1: "Address"	RD1: "ErrN°"
Run	1	1	1	0	0	0	Sensors to enter "Run Mode" (Broadcast Message to all sensors)	RC: "o.K."	RC: "Error"
							RD1: "0000"	RD1: "ErrN°"	
Execute device specific function (Short Data Frame)									
Condition: SAdr = "001" to "110" and F2="1"									
Exec 1	Sensor Address 001 .. 110			1	0	0	Execute Specific Function #1	RC: "o.K."	RC: "Error"
Exec 2				1	0	1	Execute Specific Function #2		
Exec 3				1	1	0	Execute Specific Function #3		
Exec 4				1	1	1	Execute Specific Function #4		
							RD1: Specific	RD1: "ErrN°"	
Read / Write Command (Long Data Frame)									
Condition: F2="0" and F1="1"									
RD_L	Sensor Address			0	1	0	Read nibble or byte from sensor*	RC: "o.K."	RC: "Error"
WR_L	001 .. 110			0	1	1	Write nibble or byte to sensor*	RD1: Data_Lo	RD1: "ErrN°"
								RD2: Data_Hi**	RD2: "0000"
Read / Write Command (XLong Data Frame)									
Condition: F2="0" and F1="0"									
RD_X	Sensor Address			0	0	0	Read data byte from sensor	RC: "o.K."	RC: "Error"
WR_X				0	0	1	Write data byte to sensor	RD1,RD2: Data	RD1: "ErrN°"
								RD2: "0000"	

*) Nibble (4 Bit) or Byte (8 Bit) instruction depending on device internal memory organization.

**) In case of Nibble (4 Bit) transmission Data_Hi has to be zero.

5.3.3 Returned Error Codes – Sensor Response for Frame 1-3

Table 34: Returned error codes – Sensor response for Frame 1-3

Err N°	Mnemonic	Description
0000	General	General Error*
0001	Framing	Framing Error
0010	CRC	CRC Checksum Error
0011	Address	Sensor Address not supported

Technical Specification	PSI5	53 / 65
	Peripheral Sensor Interface – Base Standard	V2.3

Err N°	Mnemonic	Description
0100	FC	Function code not supported
0101	Data range	Data range (register address) not supported
0110	Write Protect	Destination address write protected
0111		Reserved
1xxx		Application specific

519 *) Unspecific, may replace all other error codes.

6 System Setup & Operation Modes

6.1 System Setup

520 Figure 37 shows a possible system setup for peripheral sensors connected to an ECU with PSI5.

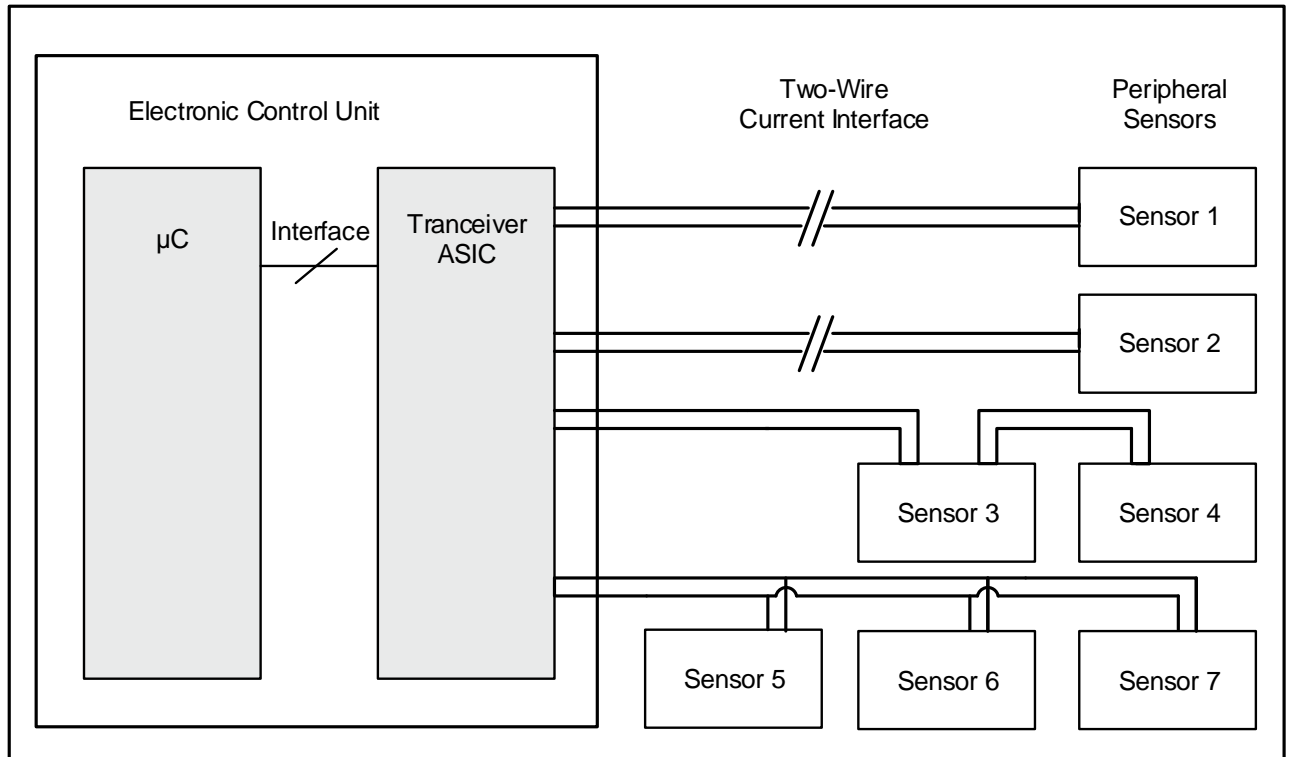

Figure 37: Connection of peripheral sensors to an ECU (Example)

521 The sensors are connected to the ECU by just two wires, using the same lines for power supply and data
 522 transmission. The transceiver ASIC provides a pre-regulated voltage to the sensors and reads in the
 523 transmitted sensor data. The example above shows a point-to-point connection for sensor 1 and 2 and two
 524 different bus configurations for sensor 3 and 4, and 5 to 7, respectively.

6.2 PSI5 Operation Modes

525 The different PSI5 operation modes define topology and parameters of the communication between ECU and
 526 sensors such as communication mode, number of data bits, error detection, cycle time, number of time slots
 527 per cycle and bit rate.

Technical Specification	PSI5	55 / 65
	Peripheral Sensor Interface – Base Standard	V2.3

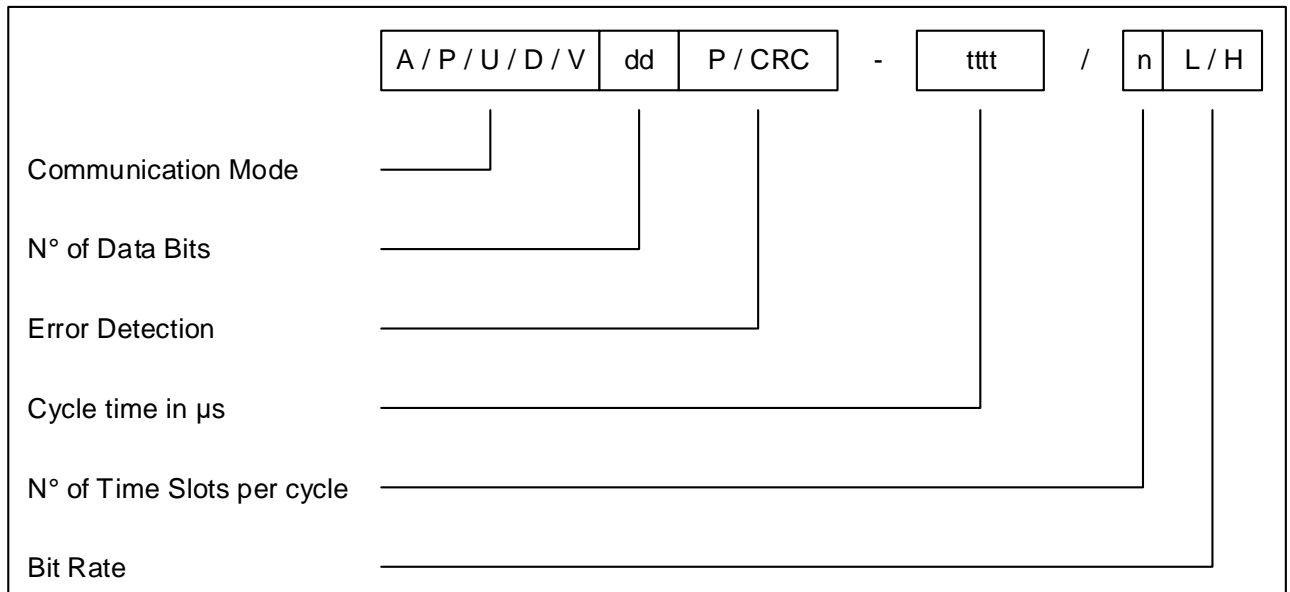

Figure 38: Denomination of PSI5 operation modes

- 528 Example “PSI5-P10P-500/3L”:
529 PSI5 synchronous parallel bus operation, 10 data bits with parity bit, 500µs sync cycle time with three time
530 slots and a standard 125 kbps data rate.

Table 35: PSI5 operation modes

Communication Modes	
A	Asynchronous Mode
P	Synchronous Parallel Bus Mode
U	Synchronous Universal Bus Mode
D	Synchronous Daisy Chain Bus Mode
V	Variable Time Triggered Synchronous Operation Mode
Error Detection	
P	One Parity Bit
CRC	Three Bits Cyclic Redundancy Check
Bit Rate	
L	125 kbps
H	189 kbps
Cycle time	
tttt	cycle time in µs (e.g. 500)
	or minimum allowed cycle time in µs for variable time triggered operation (e.g. 228)

Technical Specification	PSI5	56 / 65
	Peripheral Sensor Interface – Base Standard	V2.3

6.3 Asynchronous Operation (PSI5-A)

531 PSI5-A describes a point-to-point connection for unidirectional, asynchronous data transmission. Each sensor
 532 is connected to the ECU by two wires. After switching on the power supply, the sensor starts transmitting data
 533 to the ECU periodically. Timing and repetition rate of the data transmission are controlled by the sensor.

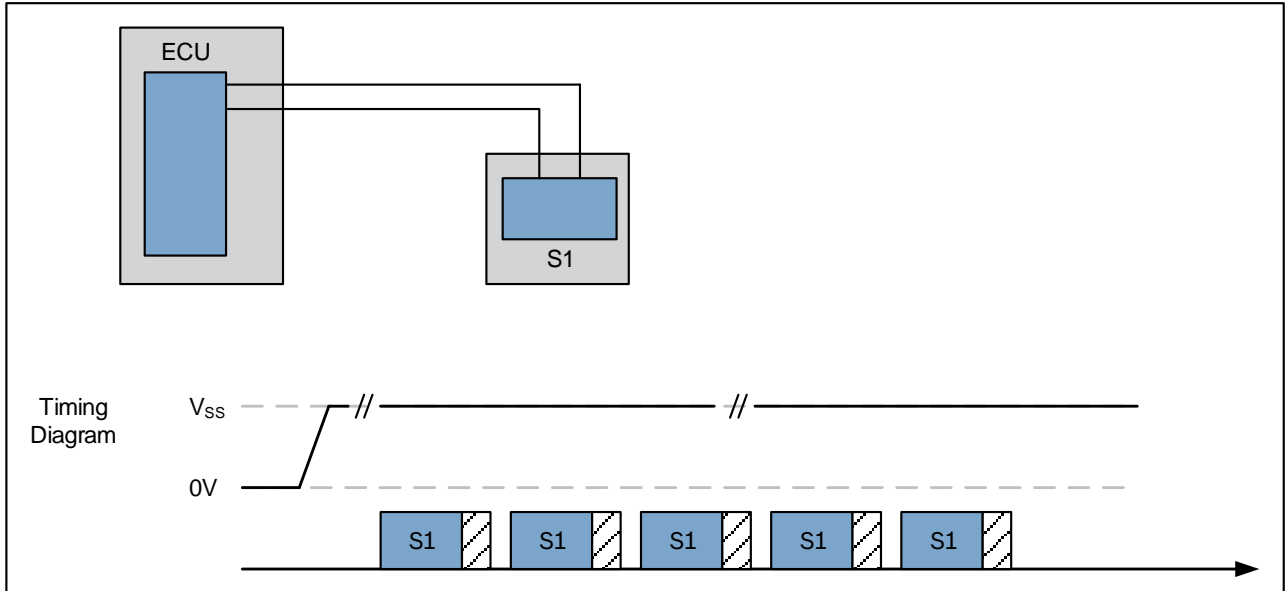

Figure 39: PSI5-A asynchronous point-to-point connection

6.4 Synchronous Operation

534 The synchronous operation modes work according to the TDMA method (Time Division Multiple Access). The
 535 sensor data transmission is synchronized by the ECU using voltage modulation. Synchronization can optionally
 536 be used for point-to-point configurations and is mandatory for bus modes.

All rights including industrial property rights and all rights of disposal such as copying and passing to third parties reserved.

6.4.1 Timing of Synchronous Operation Modes

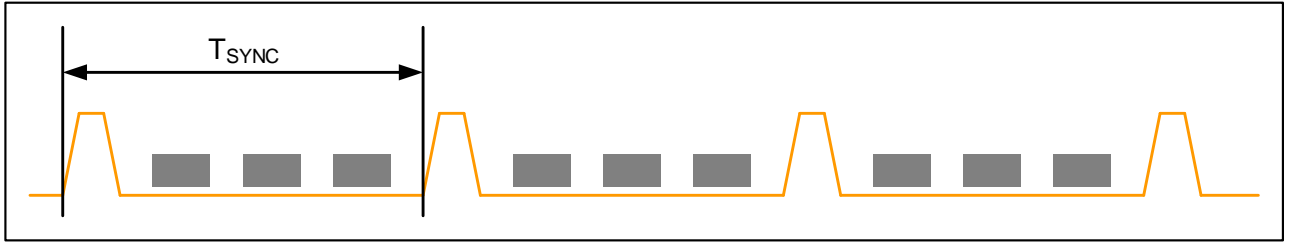

Figure 40: Fixed time triggered synchronous operation

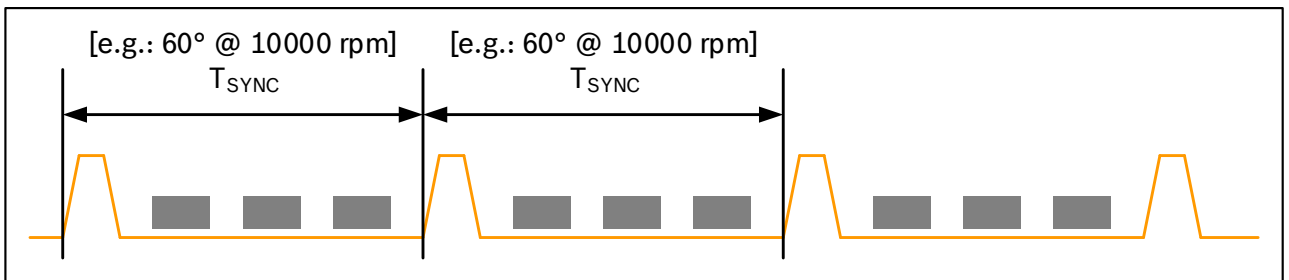

Figure 41: Variable time triggered synchronous operation

6.4.2 Bus Operation Principle

537 In the PSI5 bus topologies, one or more sensors are connected to the ECU in parallel.

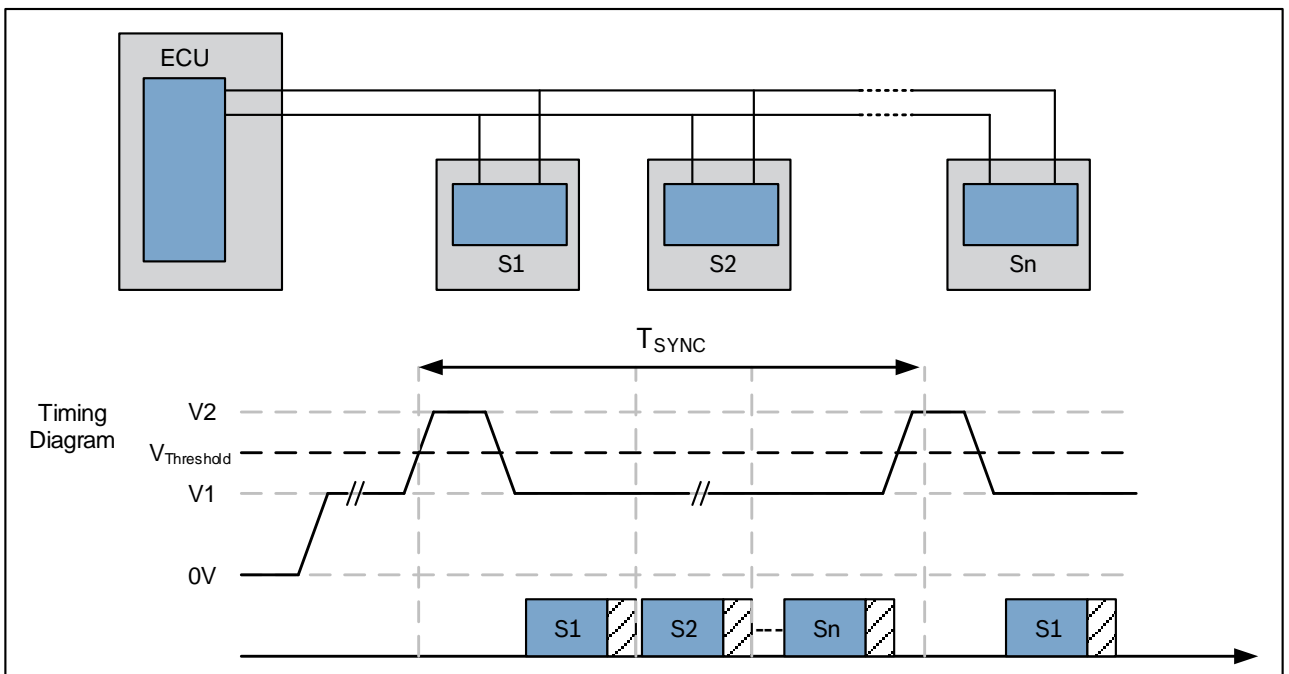

Figure 42: Basic PSI5 bus topology

538 Each data transmission period is initiated by a voltage synchronization signal from the ECU to the sensors.
 539 Having received the synchronization signal, each sensor starts transmitting its data with the corresponding
 540 time shift in the assigned time slot.

541 In a parallel bus configuration, an individual identification of the sensors is required. Alternatively the sensors
542 can be connected in a “Daisy Chain” configuration to the ECU. In this configuration the sensors have no fixed
543 address and can be connected to each position on the bus. During startup, each sensor receives an individual
544 address and then passes the supply voltage to the following sensor subsequently. The addressing is realized
545 by bidirectional communication from the ECU to the sensor using a specific sync signal pattern. After having
546 assigned the individual addresses, the sensors start to transmit data in their corresponding time slots in the
547 same way as specified in the parallel bus topology.

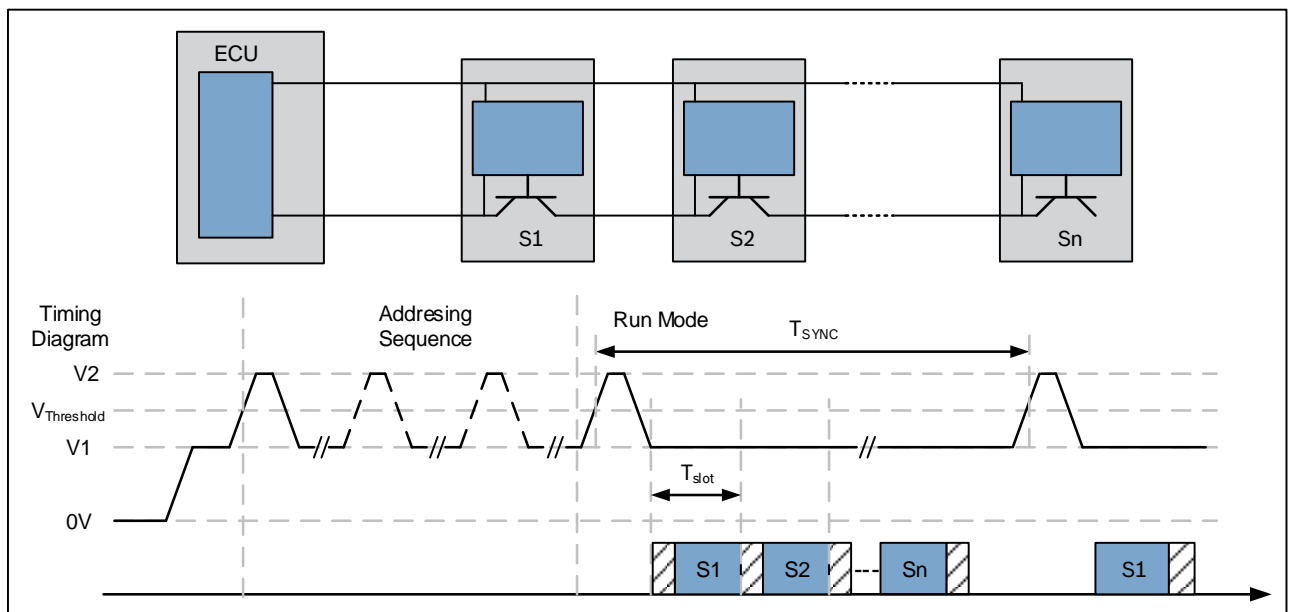

Figure 43: Daisy chain bus topology

6.4.2.1 Preferred Daisy-Chain Mode: Parallel Initialization Phase⁴⁾

548 The aim of this section is to provide some guidelines applicable for a PSI5 interface when it is operated in
549 Daisy-Chain mode, and especially to enhance the application layer specification for this mode.

550 In this operation mode, each sensor sends out the initialization sequence over the previously assigned sensor
551 time slot. The timeslot is assigned by an address setting instruction. The ECU shall assign the addresses in
552 reverse order, i.e. that timeslot TS1 is the last one receiving its address. Furthermore, timeslot TS1 is defined
553 as being the default timeslot for sensor error reporting in case of an unsuccessful address assignment.

Principle of operation

- 555 1. ECU applies supply voltage to PSI5 Interface (power on)

⁴⁾ Valid from PSI5 Technical Specification V2.1 onwards and for all Substandards except Powertrain Substandard. For backward compatibility with PSI5 V1.3 for airbag application a thorough description is given within the Airbag Substandard.

- 556 2. Wait for supply settling time
- 557 3. ECU assigns sensor address for time slot “TSi” to the next sensor that has not yet received its
- 558 configuration
- 559 4. Addressed sensor responds by sending its internal status (acknowledge or error) message and
- 560 address confirmation. Sensor closes daisy-chain switch to supply next sensor.
- 561 5. Repeat steps 2, 3 and 4 until all sensor addresses have been successfully assigned (From TSn
- 562 down to TS1)
- 563 6. ECU to send RUN broadcast instruction to start runtime mode
- 564 7. All sensors to send out their initialization data within their assigned timeslot
- 565 8. All sensors to send out “sensor_OK” messages
- 566 9. All sensors to send out their sensor data

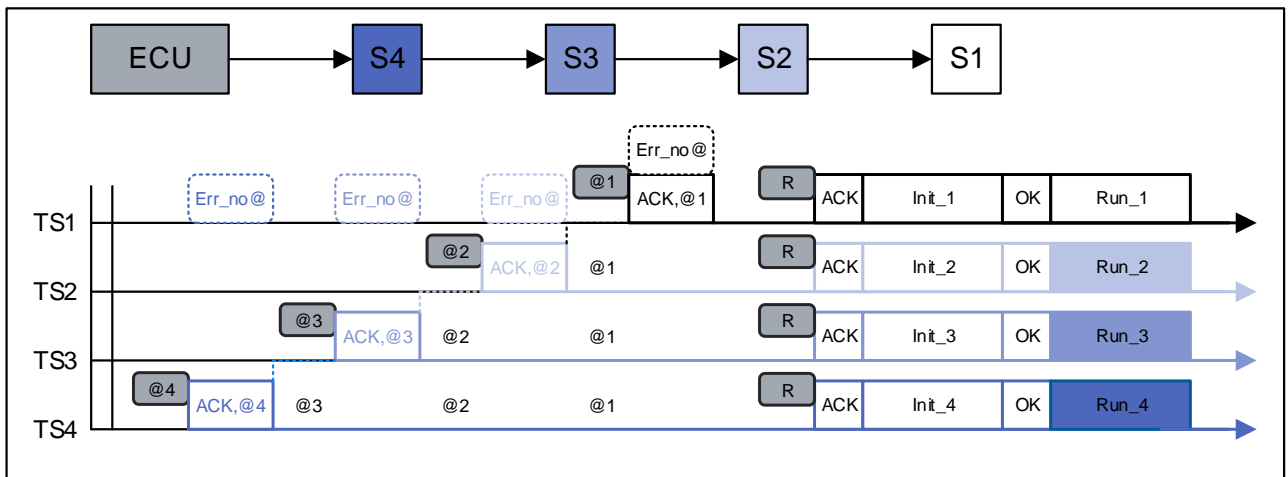

Figure 44: Daisy chain bus implementation (example with 4 time slots)

6.4.3 Sensor Cluster / Multichannel

- 567 In a sensor cluster configuration, one physical sensor contains two or more logical channels. Examples could
- 568 be a two channel acceleration sensor or a combined temperature and pressure sensor.
- 569 The data transmission of the different channels can be realized by splitting up the data word of each data
- 570 frame into two or more blocks or by transmitting the data for the different channels in separate data frames
- 571 using time multiplex.

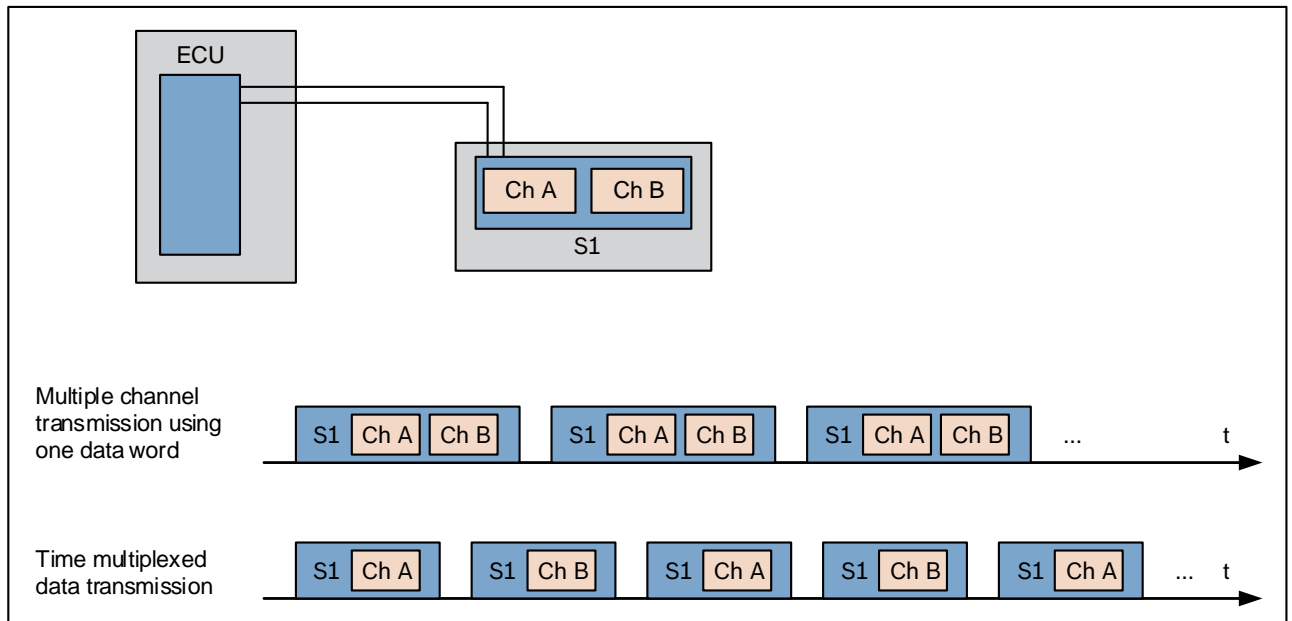

Figure 45: Implementation example sensor cluster

572 Sensor cluster / multichannel operation modes can be combined with both asynchronous and synchronous
573 data transmission and with the different bus configurations.

Technical Specification	PSI5	61 / 65
	Peripheral Sensor Interface – Base Standard	V2.3

7 Interoperability Requirements

574 PSI5 defines all basic characteristics of an electrical sensor interface including the physical layer, data link
575 layer and - to a certain extend - the application layer. Interoperability between ECU and sensors (asynchronous
576 / synchronous mode) or bus (parallel / universal bus mode and daisy chain mode) requires the definition of the
577 following additional, system specific parameters:

- 578 • Sensor configurations, operation modes and timings (single sensor, bus configuration or sensor cluster)
- 579 • System supply voltage (low, standard or increased)
- 580 • Current driving capabilities vs. current load of the sensors (standard or extended)
- 581 • Initialization data content i.e. also including determination of the repetition count (k)

582 Other sensor parameters such as mechanical and dimensional characteristics, signal evaluation path and
583 functional characteristics or reliability and environmental test conditions are beyond the scope of the PSI5
584 specification and have to be specified in separate documents to assure cross compatibility.

Technical Specification	PSI5 Peripheral Sensor Interface – Base Standard	62 / 65
		V2.3

8 Document History & Modifications

Rev.N°	Chapter	Description / Changes	Date
1.0	all	First Edition	15.07.2005
1.1	div.	see Version 1.1	30.06.2006
1.2	1.2	Optional 189kbps data transmission speed added	12.06.2007
	2.3	Synchronous operation: new denomination for operation modes	
	2.3.2	Serial topology: changed from voltage shift method to low-side “daisy chain” switching with bidirectional addressing sequence	
	3.3.1	Data Range: Updated Status & Error Messages	
	3.3.2	Scaling of data range: definition for initialization data added	
	3.4.1	Description of Initialization phase extended	
	3.4.2	Initialization data content summarized in Chapter 3.4.3; Mandatory header information includes F5 - sensor parameter.	
	4	Structure of parameter specification reorganized; General parameters (4.1) : - Quiescent current 4 .. 19mA, extended current max. 35mA - Current limitation added Data transmission parameters (4.4) : - correction of start bit values in the data frame timing figure - bit time for 189kbps mode added - communication current tolerance narrowed - fall / rise time communication current changed (see Chapter 5) - clock drift rate specified Synchronization signal (4.5): - detailed specification of only one, unified sync signal Timing of synchronous operation modes (4.6): - specification of time slots	
	5	System configurations (new Chapter): - denomination of PSI5 operating modes specified (5.1) - recommended operating modes (5.2) - detailed system configuration: asynchronous operation (5.4) - detailed system configuration: parallel bus modes (5.5.1, 5.5.2) - detailed system configuration: serial bus mode (5.6) - reference networks & test conditions (5.7) - operation modes PSI5-P10P (5.8)	
	1.3	div.	
2.2		Shifted from Chapter 5.	

Technical Specification	PSI5 Peripheral Sensor Interface – Base Standard	63 / 65
		V2.3

		Denomination of operation modes changed: - Asynchron - Parallel Bus (Parallel Configuration) - Universal Bus (Pass-Through Configuration) - Daisy Chain Bus (Serial Configuration)	
	2.3;2.4	Simplified diagrams of sensor configurations shifted from Chapter 5	
	3	Chapter renamed: Sensor to ECU Communication	
	3.4.4	Diagnostic Mode added.	
	4	Chapter added: ECU to Sensor Communication	
	5.1.1	Reverse polarity protection: - 100ms replaced by 80ms and 50ms respectively - min value of 105mA for standard mode	
	5.1.2	- Supply voltage for Universal Bus and Daisy Chain Bus added - Daisy Chain Sensor Quiescent Current added	
	5.2	Optional settling time for Daisy Chain Bus added	
	5.3	Figure replaced for clarity	
	6.3	Min value for capacitive sensor bus load changed to 6nF	
	6.4	Parameter Specification for Universal Bus added	
	6.5	Parameter Specification for Daisy Chain Bus added	
	6.6.1	- Definition of max value for supply voltage instead of nominal value - Definition of min and max value for ECU internal capacitance instead of nominal value - Sensor damping behavior redefined	
	6.6.2	Reference network for Universal Bus Mode and Daisy Chain Bus Mode added	
	7.2	Recommended Configurations shifted from Chapter 5.2	
2.0		Full revision; plus technical changes, amendments and formal changes of the document structure. Application specific Substandards “airbag”, “vehicle dynamics control” and “powertrain” are added to the PSI5 “Base Standard” document. Main features are: Changes to Physical Layer: optional Vss voltage level 4,0V; bidirectional communication downstream with short & long sync signal; optional reduced sync voltage; reduced sending current Changes to Data Link Layer: enhanced data word length up to 28bit; initialization option based on "Serial Channel"	06/2011
2.1		Full revision plus technical changes (see below)	10/2012

Technical Specification	PSI5 Peripheral Sensor Interface – Base Standard	64 / 65
		V2.3

	2.4.2	Daisy Chain implementation added	
	3.2	Explicit definition added that both start bits always are coded as two "zeros"	
	3.3.1	- Signification for reserved Data in Data Range 1 and 2 changed - Status & Error Messages; signification +489 "Sensor in Diagnostic Mode" renamed	
	4.1	Tooth Gap Method connected to the usage of the "short" sync pulse only	
	5.2.2	Xlong Data Frame: Definition of Sensor Response RD2 added	
	6.2	settling time quiescent current changed to 10ms	
	6.3	Undervoltage Reset and Microcut Rejection; split definition in base document (general) and Substandard (application specific min/max values for the affected parameters)	
	6.4	Sensor clock deviation during data frame widened for Chassis and power train applications, two alternative options defined in base specification (0.1%; 1%)	
	6.6.1	Additional explanations given for time slot calculation	
	7.6.4 7.7	Change of Test Parameter Specification, ECU reference test added, additional explanations.	
	div.	Editorial changes, consecutive line numbers for traceability	
2.2	1.1	Updated members	05/2016
	3.4	Example of CRC Calculation	
	5.1.2	Added section "Data Content – Data Range Initialization"	
	6.1	New parameter definition "signal noise limit" and "quiescent current drift rate"; detailed explanation of absolute maximum ratings	
	6.1.2	Quiescent current drift rate changed from 1 mA/s to 10 mA/s	
	6.1.2	Sync signal upper boundary (16.5V)	
	6.1.2	Signal noise limit defined (+/- 2mA for common mode)	
	6.2.1	New Chapter "Sensor Bus Configuration", settling time quiescent current changed to 5ms (larger settling times to be addressed in new Chapter "extended settling time")	
	6.2.2	New Chapter "6.2.2 Extended Settling Time for single sensor configuration"	
	6.4	Maximum sensor clock deviation during data frame changed from 0.1% to 1%.	
	div.	Editorial changes, Term "recommended" mainly removed from standard. Standardization of document naming.	

All rights including industrial property rights and all rights of disposal such as copying and passing to third parties reserved.

Technical Specification	PSI5 Peripheral Sensor Interface – Base Standard	65 / 65
		V2.3

2.3	2	Chapter “Definition of Terms” introduced with Symbol/Parameter Definitions, Glossary and Acronyms, Abbreviations	31.07.2017
	3	Chapter “Data Link Layer” introduced which consolidates all relevant definitions concerning PSI5 data link layer; consolidated information deleted out of former chapters	
	4	Chapter “Physical Layer” introduced which consolidates all relevant definitions concerning PSI5 physical layer; consolidated information deleted out of former chapters	
	4.7.1	Chapter “Supply and Communication Parameters Definitions” introduced. Figure 22: System current and voltage definitions added. Table 15: Parameter specification of absolute maximum ratings added which defines common and low power mode with related physical layer compilations	
	4.7.3	Definitions and explanations for Supply Voltages, Supply Voltage operation options and Interface Current operation options added. Former separate table for Common Mode and Low Power Mode consolidated in Table 16: Parameter compilation for Common Mode and Low Power Mode operation	
	4.9	Explanation added for different sync pulse levels with linked parameters	
	4	Introduced “Conditions/Remark” column to all tables	
	div.	Table captions and list of tables added. List of figures added. All figures have been redrawn. Line numbering has been completely reworked. Document has been completely reformatted.	

All rights including industrial property rights and all rights of disposal such as copying and passing to third parties reserved.