

Peripheral Sensor Interface for Automotive Applications

All rights including industrial property rights and all rights of disposal such as copying and passing to third parties reserved.

Content

1	Introduction	3
1.1	Description	3
1.2	PSI5 Main Features	3
1.3	Scope	3
1.4	Legal Information	4
2	System Setup & Operation Modes	5
2.1	System Setup	5
2.2	PSI5 Operation Modes	6
2.3	Asynchronous Operation (PSI5-A).....	7
2.3.1	Asynchronous Single Sensor Configuration	7
2.4	Synchronous Operation	8
2.4.1	Bus Operation Principle	8
2.4.2	Synchronous Parallel Bus Mode (PSI5-P).....	10
2.4.3	Synchronous Universal Bus Mode (PSI5-U)	11
2.4.4	Synchronous Daisy Chain Bus Mode (PSI5-D)	12
2.5	Sensor Cluster / Multichannel	13
3	Sensor to ECU communication	14
3.1	Physical Layer	14
3.1.1	Bit Encoding - Sensor to ECU Communication	14
3.1.2	Synchronization	14
3.2	Data Link Layer	15
3.2.1	Data Frames - Sensor to ECU Communication.....	15
3.2.2	Error Detection	16
3.3	Data Range	17
3.3.1	Data Range (10 Bit)	17
3.3.2	Scaling of Data Range	18
3.3.3	Data Range (16 Bit)	18
3.4	Initialization.....	19
3.4.1	Sensor Start-Up and Initialization	19
3.4.2	Initialization Data Format	20
3.4.3	Initialization Data Content	21
3.4.4	Diagnostic Mode	21
4	ECU to Sensor Communication.....	22
4.1	Physical Layer	22
4.2	Data Link Layer	22
4.2.1	Bit Coding.....	22
4.2.2	Data Framing	22
4.2.3	Data Frames	23
4.2.4	Sensor Addresses.....	23
4.2.5	Function Codes.....	24
4.2.6	Returned Error Codes.....	24
5	Parameter Specification	25
5.1	General Parameters.....	25
5.1.1	Absolute Maximum Ratings	25
5.1.2	System Parameters	26
5.2	Sensor Power-on Characteristics	27
5.3	Undervoltage Reset and Microcut Rejection	28
5.4	Data Transmission Parameters	29
5.5	Synchronization Signal.....	30
5.6	Timing of Synchronous Operation Modes.....	33

Technical Specification	PSI5	Page 2 / 46
	Peripheral Sensor Interface	V1.3

6	System Configuration & Test Conditions	34
6.1	System Modelling	34
	6.1.1 Supply Line Model	34
6.2	Asynchronous Mode	34
6.3	Parallel Bus Mode	35
6.4	Universal Bus Mode	35
6.5	Daisy Chain Bus Mode	36
6.6	Test Conditions & Reference Networks – Sensor Testing	37
	6.6.1 Reference Networks for Asynchronous Mode and Parallel Bus Mode	37
	6.6.2 Reference Networks for Universal Bus Mode and Daisy Chain Bus Mode	39
	6.6.3 Test Parameter Specification	39
	6.6.4 Sensor Reference Tests for Asynchronous Mode and Parallel Bus Mode	40
	6.6.5 Sensor Reference Tests for Universal Bus Mode and Daisy Chain Bus Mode	41
6.7	Test Conditions & Reference Networks - Receiver / ECU Testing	41
6.8	Operation Modes	42
	6.8.1 PSI5-P10P-500/3L Mode	42
	6.8.2 PSI5-P10P-500/4H Mode	42
7	Appendix A	43
7.1	Interoperability Requirements	43
7.2	Recommended Configurations	43
7.3	Status Data Content	44
8	Document History & Modifications	45

Technical Specification	PSI5 Peripheral Sensor Interface	Page 3 / 46
		V1.3

1 Introduction

1.1 Description

The Peripheral Sensor Interface (PSI5) is an interface for automotive sensor applications. PSI5 is an open standard based on existing sensor interfaces for peripheral airbag sensors, already proven in millions of airbag systems. The technical characteristics, the low implementation overhead as well as the attractive cost make the PSI5 also suitable for many other automotive sensor applications.

Development goal of the PSI5 is a flexible, reliable communication standard for automotive sensor applications that can be used and implemented free of charge.

The PSI5 development and the publication of this technical specification are responsibly managed by the "PSI5 Steering Committee", formed by the companies Autoliv, Bosch, and Continental.

This PSI5 technical specification V1.3 is a joint development of the companies Autoliv, Bosch, Continental, Freescale and TRW.

1.2 PSI5 Main Features

Main features of the PSI5 are high speed and high reliability data transfer at lowest possible implementation overhead and cost. PSI5 covers the requirements of the low-end segment of digital automotive interfaces and offers a universal and flexible solution for multiple sensor applications.

- Two-wire current interface
- Manchester coded digital data transmission
- High data transmission speed of 125kbps or optional 189kbps
- High EMC robustness and low emission
- Wide range of sensor supply current
- Variable data word length (8, 10, 16, 20, 24 bit)
- Asynchronous or synchronous operation and different bus modes
- Bidirectional communication

1.3 Scope

This document describes the interface according to the ISO/OSI reference model and contains the corresponding parameter specifications. PSI5 standardizes the low level communication between peripheral sensors and electronic control units.

Technical Specification	PSI5 Peripheral Sensor Interface	Page 4 / 46
		V1.3

1.4 Legal Information

The specification may be reproduced or copied, subject to acceptance of the contents of this document.

No part of this specification may be modified or translated in any form or by any means without prior written permission of Autoliv, Bosch, and Continental. With their permission Autoliv, Bosch, and Continental assume no liability for the modifications or translations made by third parties.

In case Autoliv, Bosch, and Continental permit any of the aforementioned modifications or translations Autoliv, Bosch, and Continental shall be entitled to use such modifications or translations free of charge for future versions of the PSI5 protocol and make such future versions available to third parties under the same terms and conditions as for the PSI5 protocol.

Disclaimer

The specification and all enclosed documents are provided to you "AS IS". You assume total responsibility and risk for your use of them including the risk of any defects or inaccuracies therein.

Autoliv, Bosch, Continental, Freescale and TRW, do not make, and expressly disclaim, any express or implied warranties of any kind whatsoever, including, without limitation, implied warranties of merchantability of fitness for a particular purpose, warranties or title or non-infringement.

Autoliv, Bosch, Continental, Freescale and TRW shall not be liable for

- (a) any incidental, consequential, or indirect damages (including, without limitation, damages for loss of profits, business interruption, loss of programs or information, and the like) arising out of the use of or inability to use the specification or enclosed documents,
- (b) any claims attributed to errors, omissions, or other inaccuracies in the specification or enclosed documents.

As far as personal injuries are caused due to the specification or any of the enclosed documents and to the extent the mandatory laws of the law applicable restrict the limitation of liability in such cases or in other circumstances as for example liability due to wilful intent, fraudulently concealed defects or breach of cardinal obligations, the mandatory law applicable shall remain unimpaired.

Indemnification

You shall indemnify and hold harmless Autoliv, Bosch, Continental, Freescale and TRW, their affiliates and authorized representatives against any claims, suits or proceedings asserted or commenced by any third party and arising out of, or relating to, you using the specification or enclosed documents. This obligation shall include indemnification against all damages, losses, costs and expenses (including attorneys fees) incurred by Autoliv, Bosch, Continental, Freescale and TRW, their affiliates and authorized representatives as a result of any such claims, suits or proceedings, including any costs or expenses incurred in defending against any such claims, suits, or proceedings.

By making use of the PSI5 protocol you declare your approval with the above standing terms and conditions. This document is subject to change without notice.

2 System Setup & Operation Modes

2.1 System Setup

Figure 1 shows a typical system setup for peripheral sensors connected to an ECU with PSI5.

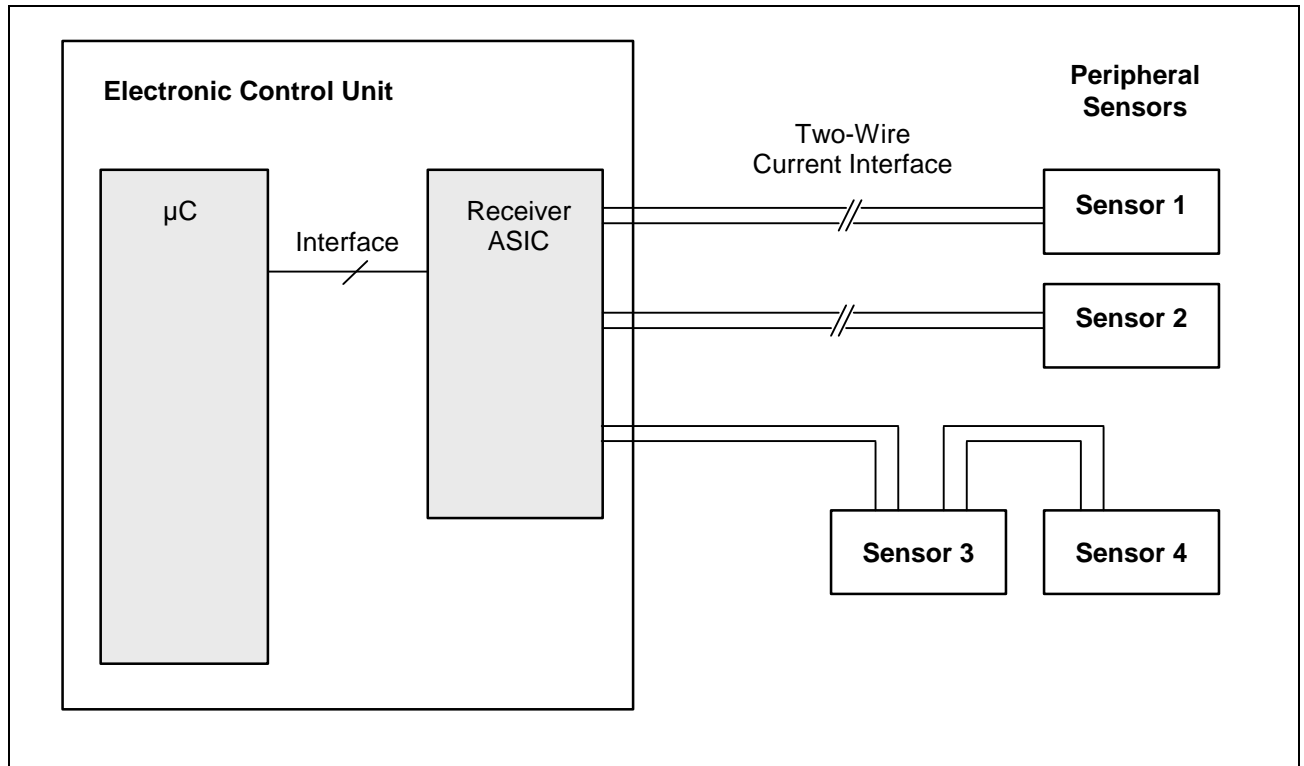

Figure 1 Connection of peripheral sensors to an ECU (Example)

The sensors are connected to the ECU by just two wires, using the same lines for power supply and data transmission. The receiver ASIC provides a pre-regulated voltage to the sensors and reads in the transmitted sensor data. The example above shows a point-to-point connection for sensor 1 and 2 and bus configuration for sensor 3 and 4.

2.2 PSI5 Operation Modes

The different PSI5 operation modes define topology and parameters of the communication between ECU and sensors such as communication mode, number of data bits, error detection, cycle time, number of time slots per cycle and bit rate.

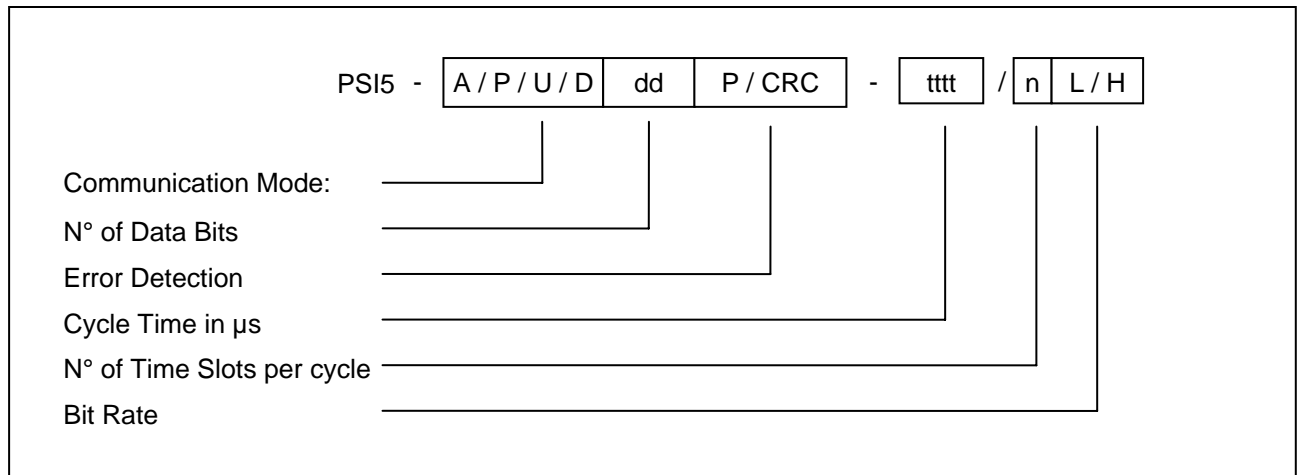

Figure 2 Denomination of PSI5 operation modes

Example "PSI5-P10P-500/3L":

PSI5 synchronous parallel bus operation, 10 data bits with parity bit, 500µs sync cycle time with three time slots and a standard 125 kbps data rate.

Communication Modes	
A	Asynchronous Mode
P	Synchronous Parallel Bus Mode
U	Synchronous Universal Bus Mode
D	Synchronous Daisy Chain Bus Mode
Error Detection	
P	One Parity Bit
CRC	Three Bits Cyclic Redundancy Check
Bit Rate	
L	125 kbps
H	189 kbps

2.3 Asynchronous Operation (PSI5-A)

PSI5-A describes a point-to-point connection for unidirectional, asynchronous data transmission.

Each sensor is connected to the ECU by two wires. After switching on the power supply, the sensor starts transmitting data to the ECU periodically. Timing and repetition rate of the data transmission are controlled by the sensor.

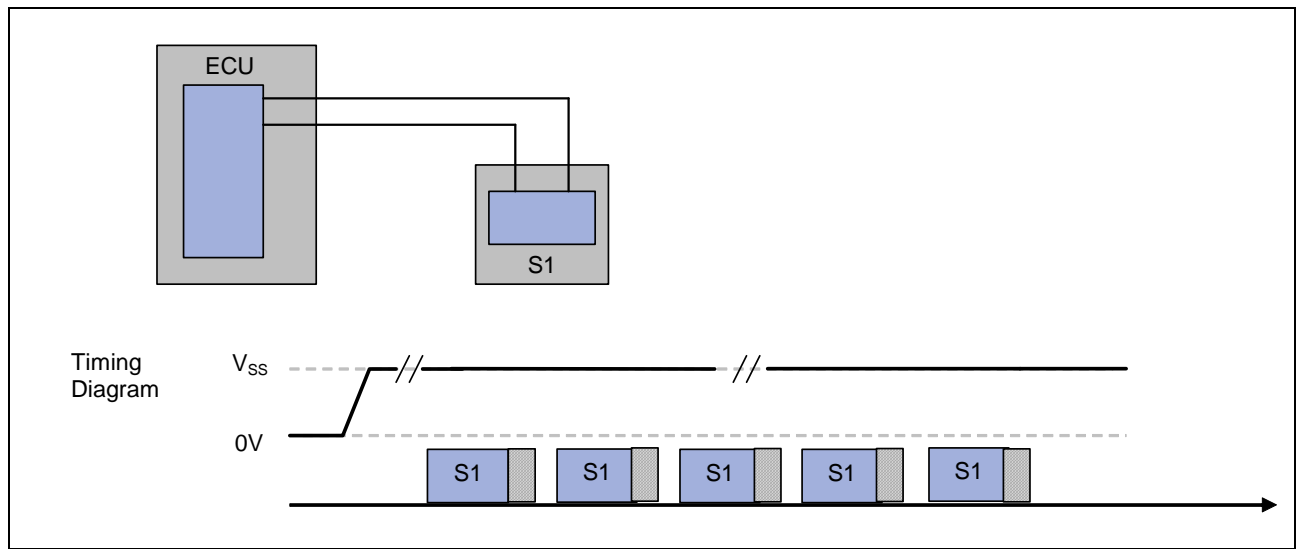

Figure 3 PSI5-A asynchronous point-to-point connection

2.3.1 Asynchronous Single Sensor Configuration

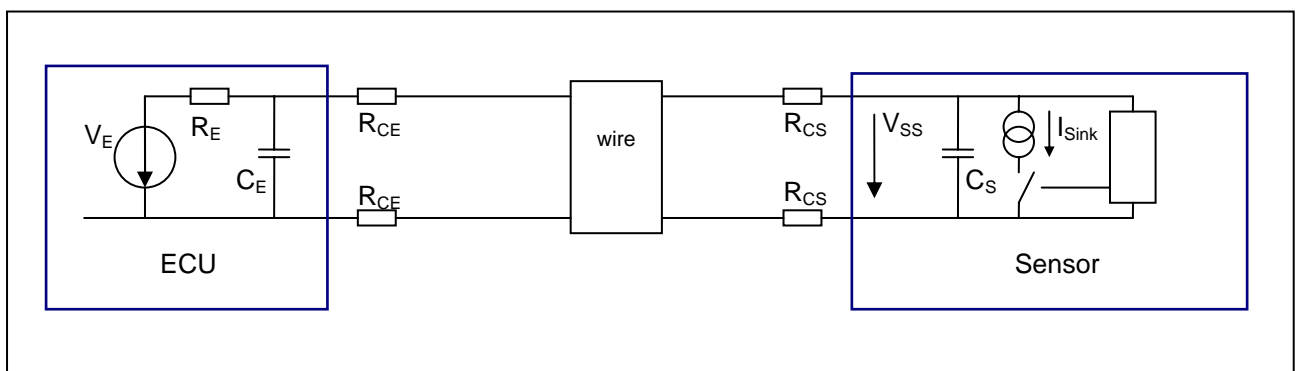

Figure 4 Single sensor configuration (simplified diagram)

2.4 Synchronous Operation

The synchronous operation modes work according to the TDMA method (Time Division Multiple Access). The sensor data transmission is synchronized by the ECU using voltage modulation. Synchronization can be optionally used for point-to-point configurations and is mandatory for bus modes.

2.4.1 Bus Operation Principle

In the PSI5 bus topologies, one or more sensors are connected to the ECU in parallel.

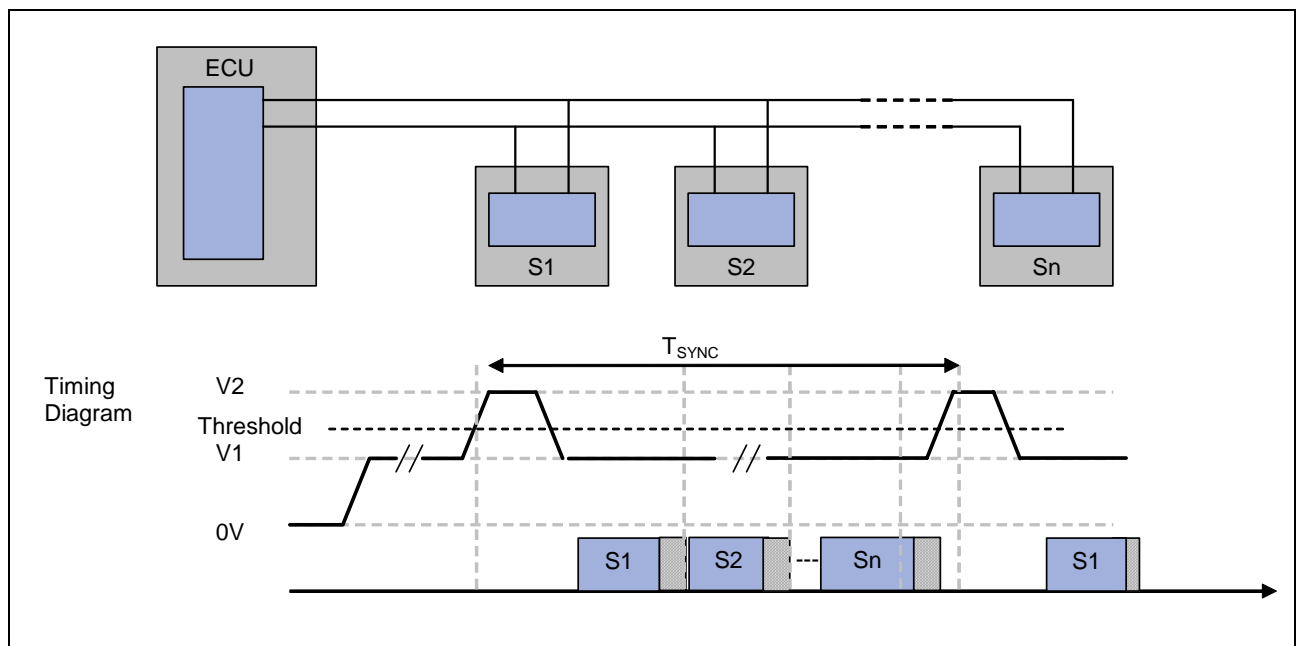

Figure 5 Basic PSI5 bus topology

Each data transmission period is initiated by a voltage synchronization signal from the ECU to the sensors. Having received the synchronization signal, each sensor starts transmitting its data with the corresponding time shift in the assigned time slot.

In a parallel bus configuration, an individual numbering of the sensors is required. Alternatively the sensors can be connected in a “Daisy Chain” configuration to the ECU. In this configuration the sensors have no fixed address and can be connected to each position on the bus. During startup, each sensor receives an individual address and then passes the supply voltage to the following sensor subsequently. The addressing is realized by bidirectional communication from the ECU to the sensor using a specific sync signal pattern. After having assigned the individual addresses, the sensors start to transmit data in their corresponding time slots in the same way as specified in the parallel bus topology.

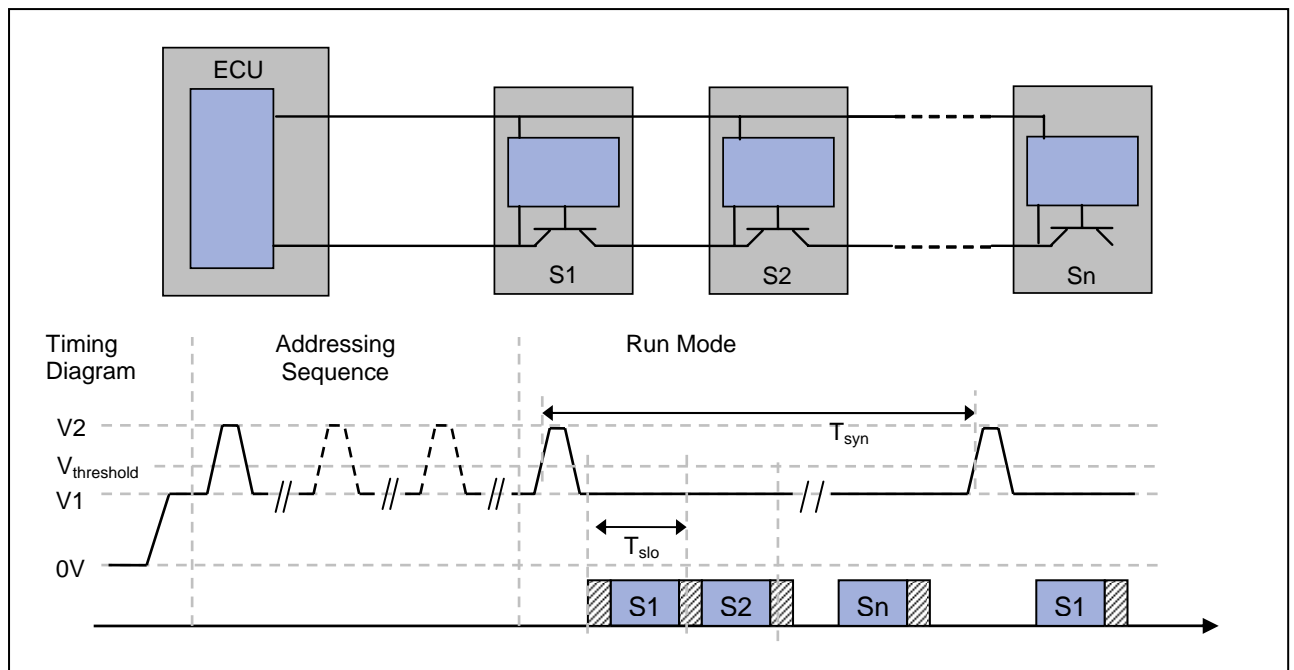

Figure 6 Daisy Chain Bus Topology

2.4.2 Synchronous Parallel Bus Mode (PSI5-P)

PSI5-P describes a bus configuration for synchronous data transmission of one or more sensors. Each sensor is connected to the ECU by a separate pair of wires (star topology).

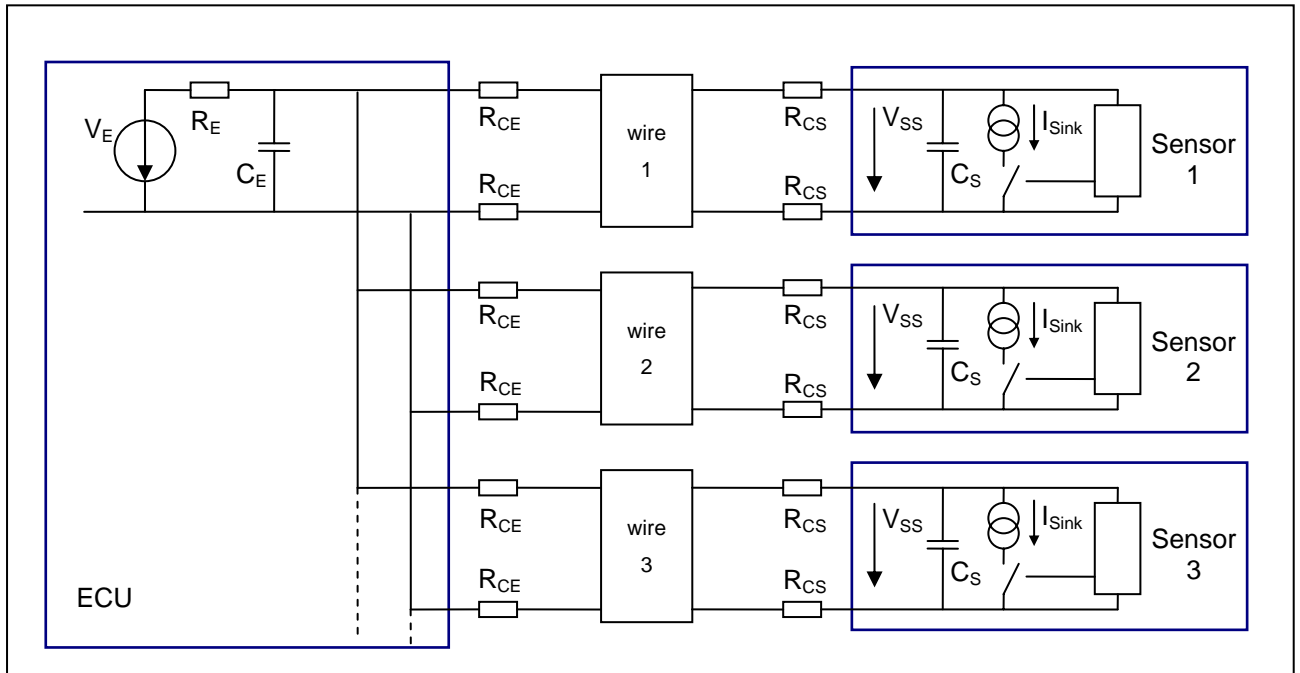

Figure 7 Synchronous Parallel Bus Mode (simplified schematic)

In order to provide an interchangeability of different sensor and receiver components, additional interface parameters for ECU, sensors, and wiring are specified for this bus mode (see chapter 6.3).

2.4.3 Synchronous Universal Bus Mode (PSI5-U)

PSI5-U describes a bus configuration for synchronous data transmission of one or more sensors. The sensors are connected to the ECU in different wiring topologies including splices or pass-through configurations.

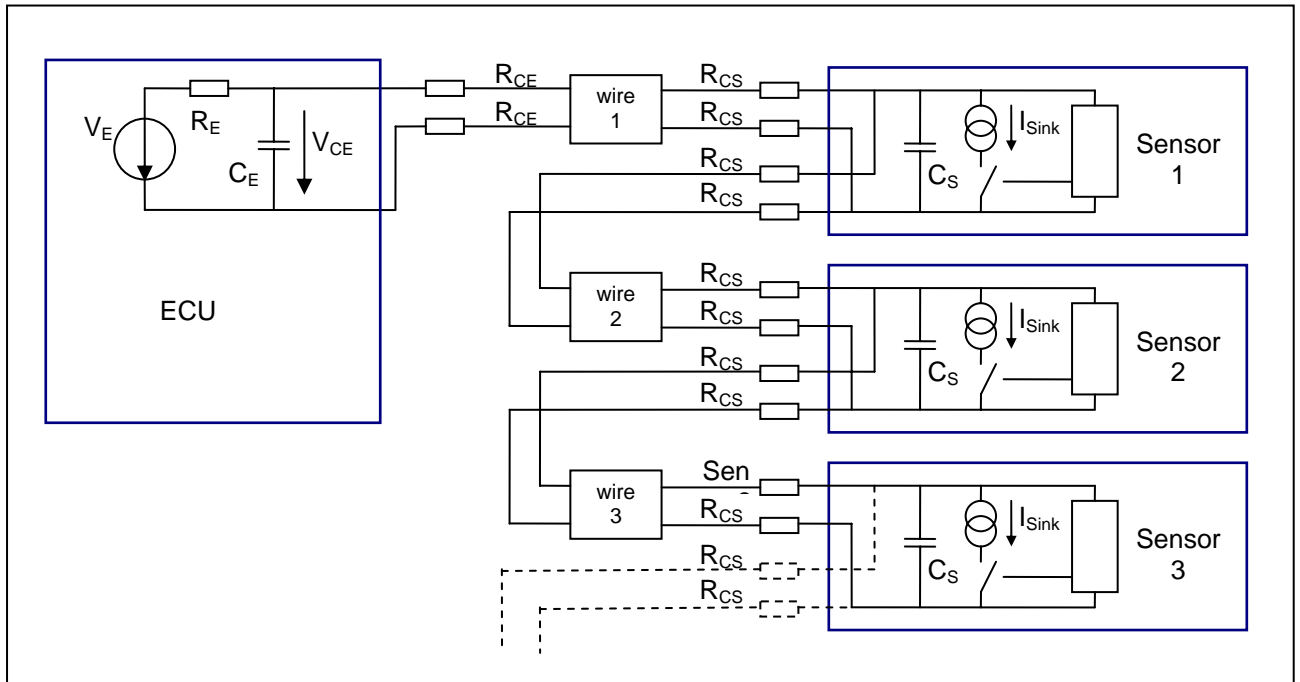

Figure 8 Example for a pass-through configuration (simplified schematic)

The wiring and sensors are considered as a “black box” resulting in a limited interchangeability of sensor and receiver components. Interface parameters are given for the ECU and the “black box” only (see chapter 6.4).

2.4.4 Synchronous Daisy Chain Bus Mode (PSI5-D)

PSI5-D describes a bus configuration for synchronous data transmission of one or more sensors connected in a daisy chain configuration. The required addressing of the sensors during start up is specified in chapter 4.2.

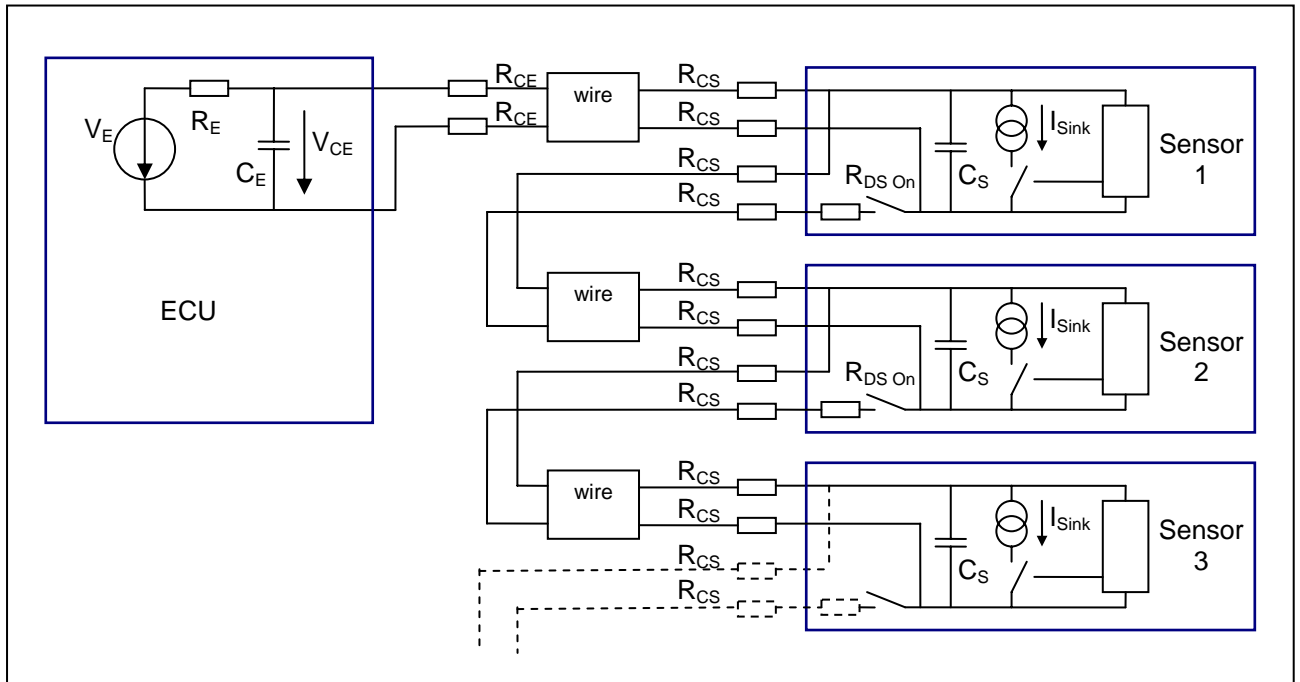

Figure 9 Synchronous Daisy Chain Bus (simplified schematic)

2.5 Sensor Cluster / Multichannel

In a sensor cluster configuration, one physical sensor contains two or more logical channels. Examples could be a two channel acceleration sensor or a combined temperature and pressure sensor.

The data transmission of the different channels can be realized by splitting up the data word of each data frame into two or more blocks or by transmitting the data for the different channels in separate data frames using time multiplex.

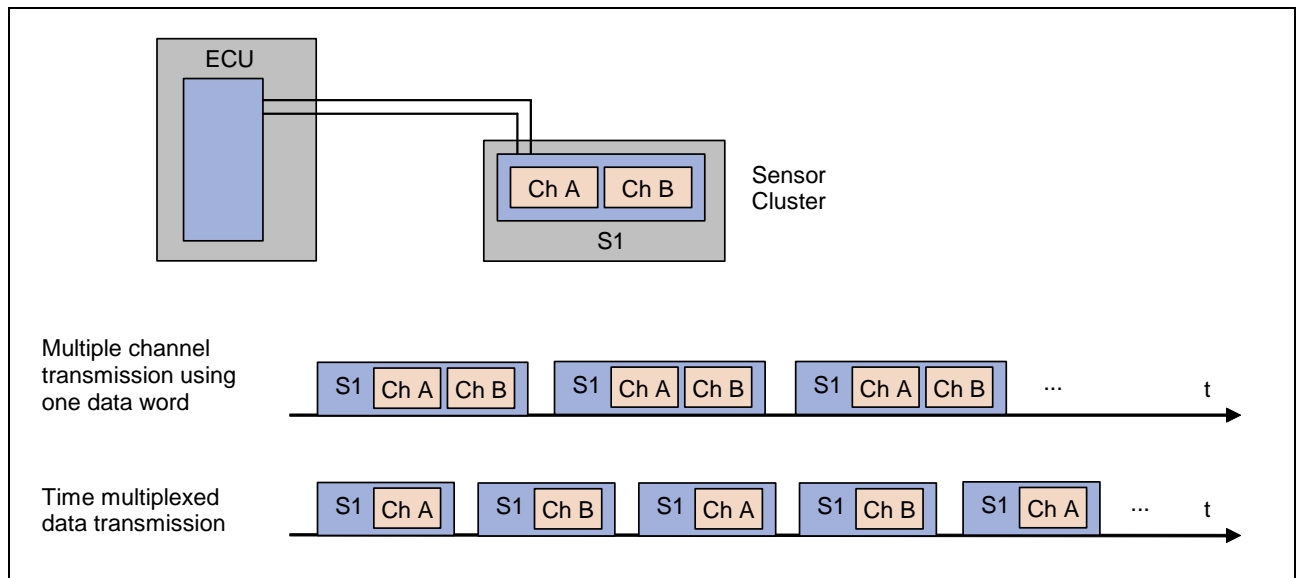

Figure 10 Sensor cluster

Sensor cluster / multichannel operation modes can be combined with both asynchronous and synchronous data transmission and with the different bus configurations.

3 Sensor to ECU communication

3.1 Physical Layer

PSI5 uses two wires for both power supply to the sensors and data transmission. The ECU provides a pre-regulated voltage to the sensor. Data transmission from the sensor to the ECU is done by current modulation on the power supply lines. Current oscillations are damped by the ECU.

3.1.1 Bit Encoding - Sensor to ECU Communication

A "low" level ($I_{S,Low}$) is represented by the normal (quiescent) current consumption of the sensor(s). A "high" level ($I_{S,High}$) is generated by an increased current sink of the sensor ($I_{S,Low} + \Delta I_S$). The current modulation is detected within the receiver ASIC.

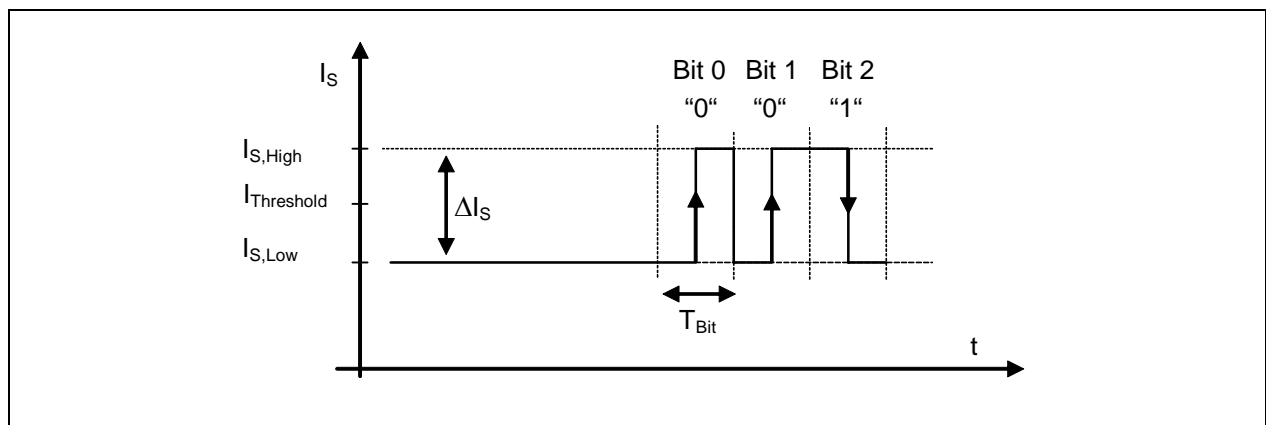

Figure 11 Bit encoding using supply current modulation

Manchester coding is used for data transmission. A logic "0" is represented by a rising slope and a logic "1" by a falling slope of the current in the middle of T_{Bit} .

3.1.2 Synchronization

For synchronized operation and bus mode, modulation of the supply voltage between the two different voltage levels is applied. The voltage change is detected within the sensors.

3.2 Data Link Layer

3.2.1 Data Frames - Sensor to ECU Communication

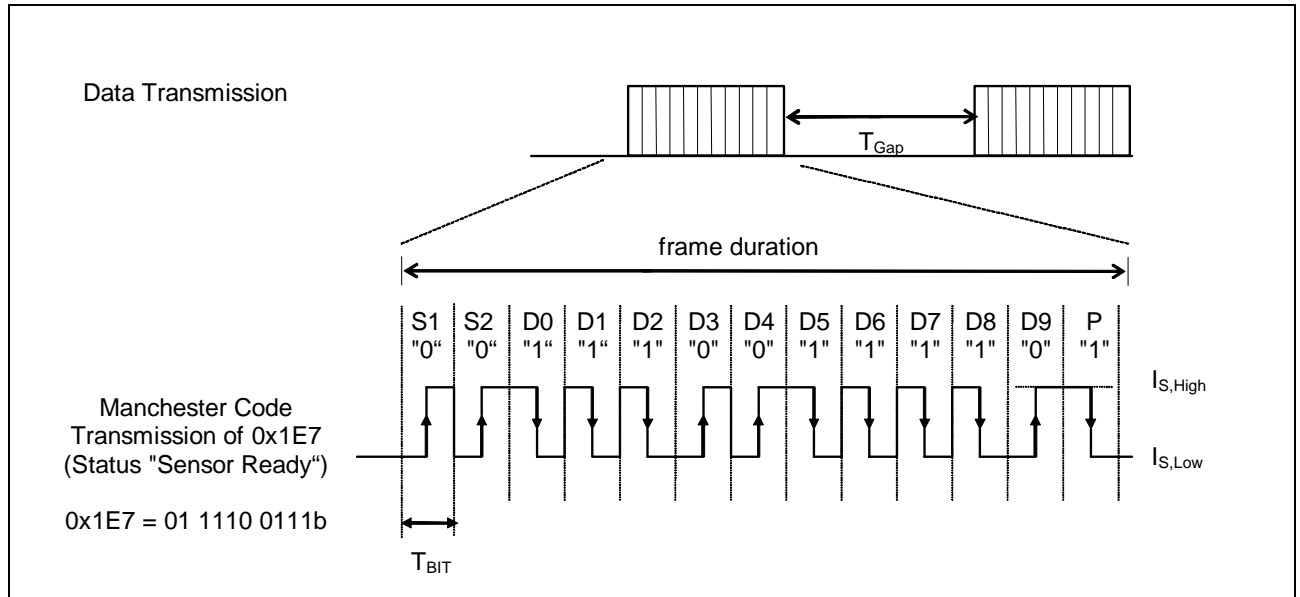

Figure 12 Example of a data frame with 10 data bits (D0-D9), 2 start bits (S1,S2) and one parity bit (P).

Each PSI5 data frame consists of N bits containing two start bits and one parity bit with even parity (or 3 CRC bits) and N-3 (N-5) data bits. Data bits are transmitted LSB first. The data frames are sent periodically from the sensor to the ECU. A minimum gap time T_{Gap} larger than one maximum bit duration T_{Bit} is required between two data frames.

3.2.2 Error Detection

Error detection is realized by a single bit even parity (recommended for 10 or less bits) or a three bit CRC (recommended for long data words). The generator polynomial of the CRC is $g(x)=1+x+x^3$ with a binary CRC initialization value "111". The transmitter extends the data bits by three zeros (as MSBs). This augmented data word shall be fed (LSB first) into the shift registers of the CRC check. Start bits are ignored in this check. When the last zero of the augmentation is pending on the input adder, the shift registers contain the CRC checksum. These three check bits shall be transmitted in reverse order (MSB first: C2, C1, C0).

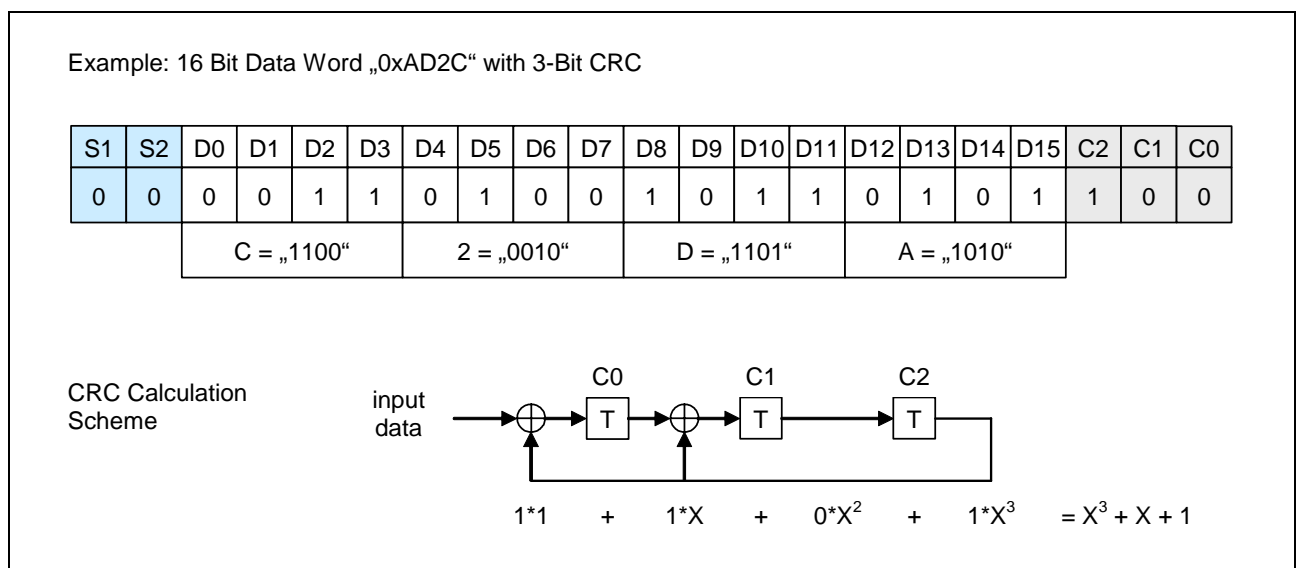

Figure 13 16 Bit Data word example with 3-Bit CRC

3.3 Data Range

PSI5 data messages are divided into three separate ranges: A data range for the sensor output signal, a range for status and error messages and a range for initialization data.

3.3.1 Data Range (10 Bit)

For 10 bit sensors, the decimal values –480 to +480 are used for the sensor output signal. The range –512 to –481 is reserved for the block and data ID's which are used for transmitting initialization data during startup of the sensor (see chapter 3.4). The range from +481 to +511 is used for status and error messages.

Dec	Hex	Signification	Range	
+511	0x1FF	Reserved (ECU internal use) *1	Status & Error Messages	2
:	:	Reserved (ECU internal use) *1		
+504	0x1F8	Reserved (ECU internal use) *1		
+503	0x1F7	Reserved (Sensor use) *2		
+502	0x1F6	Reserved (Sensor use) *2		
+501	0x1F5	Reserved (Sensor use) *2		
+500	0x1F4	"Sensor Defect"		
+499	0x1F3	Reserved (ECU internal use) *1		
:	:	Reserved (ECU internal use) *1		
+496	0x1F0	Reserved (ECU internal use) *1		
+495	0x1EF	Reserved (Sensor use) *2		
:	:	Reserved (Sensor use) *2		
+489	0x1E9	"Sensor in Diagnostic Mode"		
+488	0x1E8	"Sensor Busy"		
+487	0x1E7	"Sensor Ready"		
+486	0x1E6	"Sensor Ready but Unlocked"		
+485	0x1E5	Reserved (Sensor use) *2		
+484	0x1E4	Reserved (Sensor use) *2		
+483	0x1E3	Reserved (Sensor use) *2		
+482	0x1E2	Bidirectional Communication: RC "Error"		
+481	0x1E1	Bidirectional Communication: RC "o.K."		
+480	0x1E0	Highest Positive Sensor Signal	Sensor Output Signal	1
:	:	:		
0	0x000	Signal Amplitude "0"		
:	:	:		
-480	0x220	Highest Negative Sensor Signal	Block ID's and Data for Initialization	3
-481	0x21F	Status Data 1111		
:	:	:		
-496	0x210	Status Data 0000		
-497	0x20F	Block ID 16		
:	:	:		
-512	0x200	Block ID 1		

(*1) Usage for ECU internal purpose possible (e.g. "No Data", "Manchester Error" etc.)

(*2) Reserved for future extensions of this specification, usage not recommended.

3.3.2 Scaling of Data Range

The sensor output signal range scales with the data word length. For sensors with a data word length of more than 10 bit, status and initialization data words of range 2 and 3 are filled up with the value of the bit corresponding to the "D0" bit in the 10 Bit data word (possibility to check for stuck bits in the receiver).

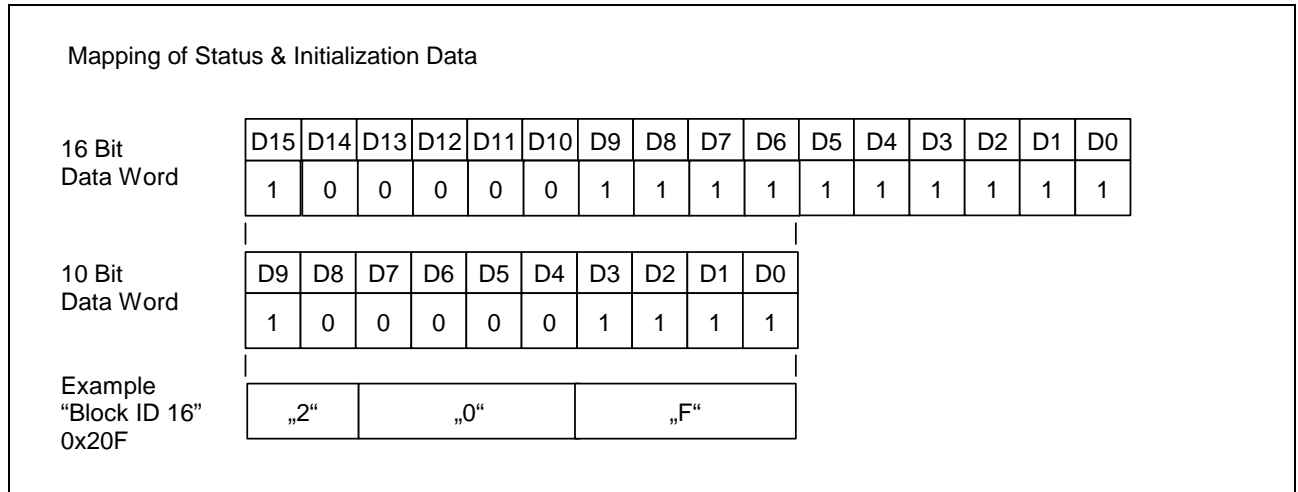

Figure 14 Mapping of status and initialization data into a data word

3.3.3 Data Range (16 Bit)

Dec	Hex	Signification	Range	
32767	0x7FFF	Reserved (ECU internal use)	Status & Error Messages	2
+31168	0x79FF	Sensor Ready		
:	:		Sensor Output Signal	1
+30720	0x7800	Highest Positive Sensor Signal		
:	:	:		
0	0x0000	Signal Amplitude "0"		
:	:	:		
-30720	0x8800	Highest Negative Sensor Signal	Block ID's and Data for Initialisation	3
-30784	0x87FF	Status Data 1111		
:	:	:		
-31744	0x8400	Status Data 0000		
-31808	0x83FF	Block ID 16		
:	:	:		
-32768	0x8000	Block ID 1		

3.4 Initialization

3.4.1 Sensor Start-Up and Initialization

After each power on or under-voltage reset, the sensor performs an internal initialization which is divided into three phases:

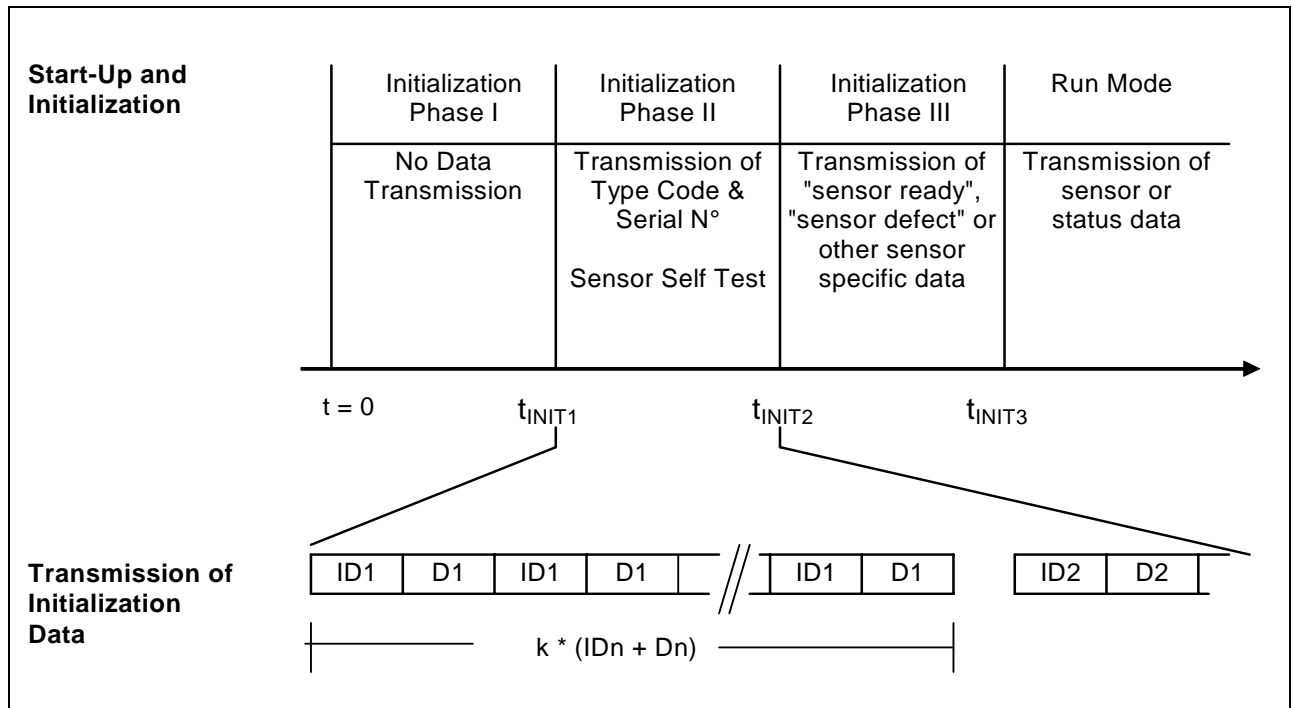

Figure 15 Initialization of the sensor

ID blocks and data blocks are sent in an alternating sequence, "k" times each. The block identifiers are used for a numbering of the following data nibbles. After any power-on or undervoltage reset, the internal logic starts up with an initialization program.

	Initialisation Phase I	Initialisation Phase III
Duration of initialization phases	t = 50...150 ms Typical: 100 ms	Minimum: 2 messages Maximum: 200 ms Typical: 10 values

During the first initialization phase, no data is transmitted and the ECU can perform a connectivity test. During the second initialization phase, the sensor transmits sensor and application specific information to the ECU. During the third initialization phase, the sensor transmits "sensor ready", "sensor defect" or other optional status data. If the sensor is defective, it will continue to send the "sensor defect" messages and other optional status data until it is powered off. The sensor status information must consist of data words out of data range 2 and 3. Usage of sensor output signal data words out of data range 1 is not allowed during initialization phases II and III.

If the initialization is finished successfully, the sensor goes into run mode and starts transmitting sensor signal data or optional status data until it is switched off or an internal error is detected.

3.4.2 Initialization Data Format

A special data format and a reserved data range are used during initialization in order to avoid possible mix-up with sensor signal data. “Data Range 3” contains each 16 block identifiers and 4-bit data nibbles (see chapter 3.3).

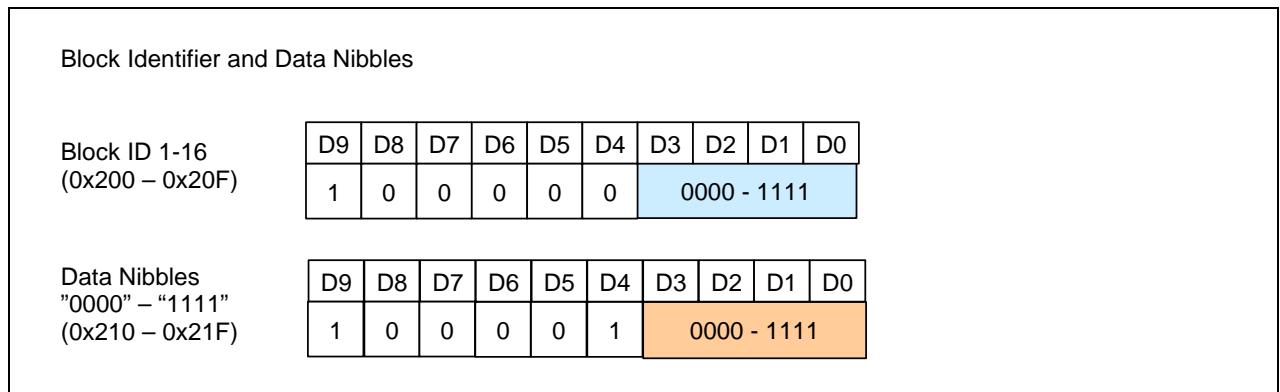

Figure 16 Block ID and Data Nibbles

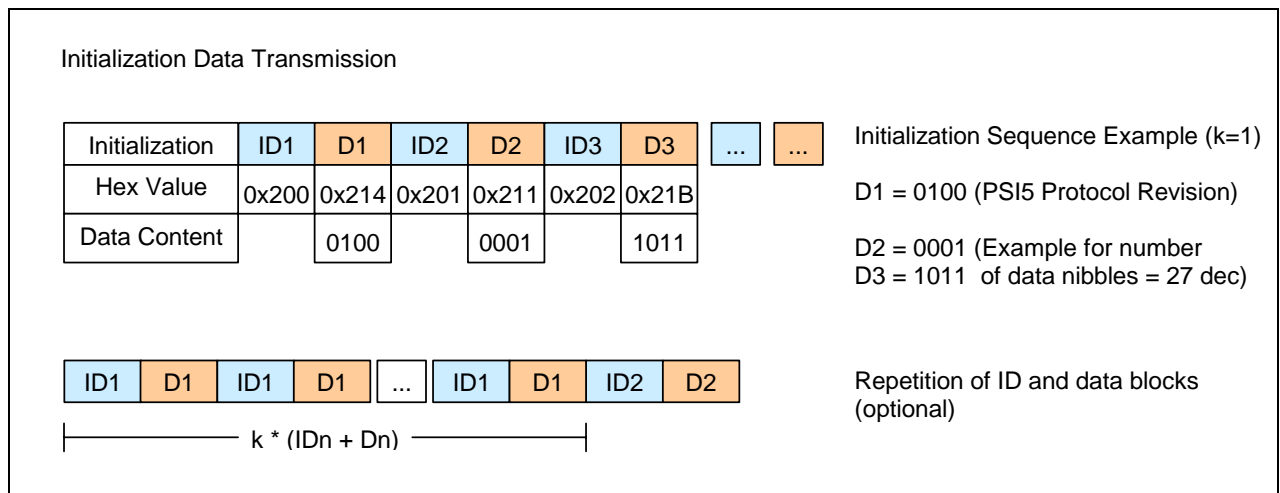

Figure 17 Startup Sequence

If the initialization data exceeds 4x16=64 bit (more than 36 bit of sensor specific information), data can be paged. The ID codes are reused for every 64 bit page of data to be transmitted. Data pages are not numbered. Mapping of the information contained in different data pages has to be derived from the chronology of the startup sequence. It is not mandatory to transmit complete data pages.

The initialization data is based on a 10 bit data word length (see chapter 3.3).

3.4.3 Initialization Data Content

The initialization data contains the following information:

- PSI protocol revision
- Total number of data blocks (nibbles) transmitted during initialization
- Manufacturer Code
- Sensor Type
- Sensor and application specific information

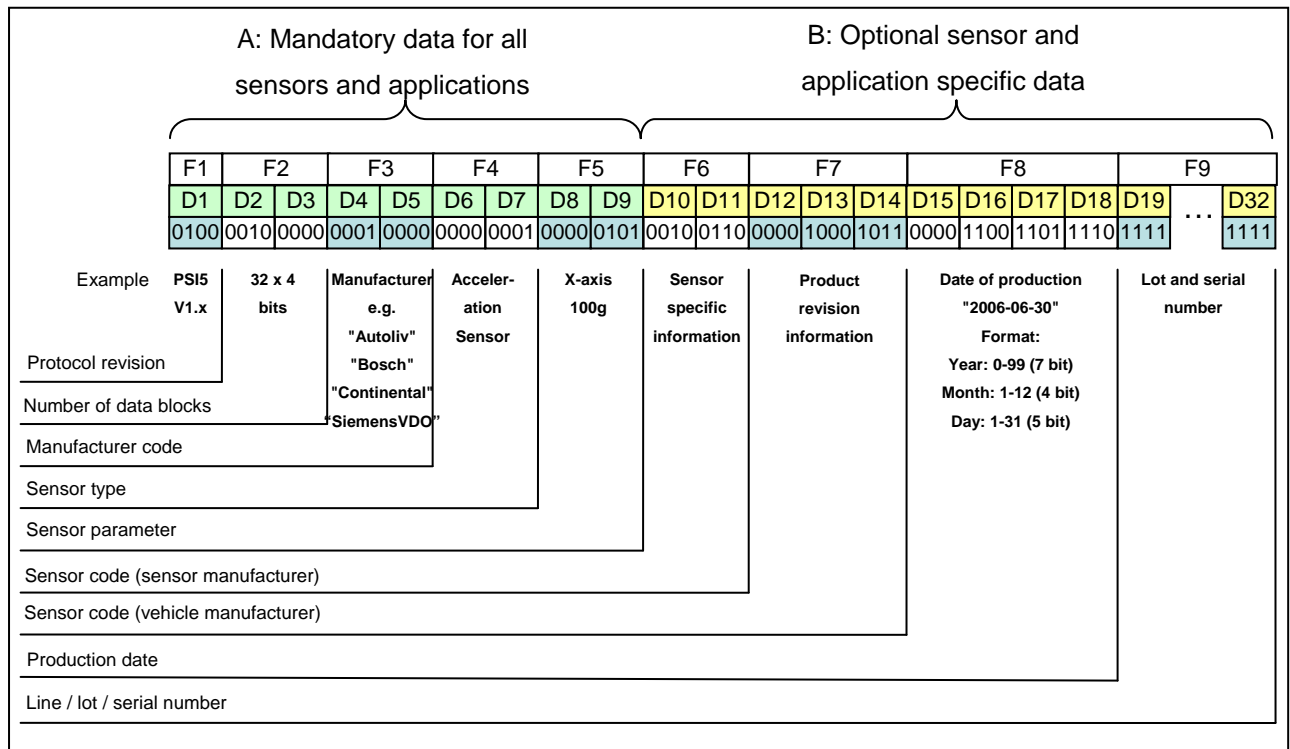

Figure 18 Initialization phase 2: Recommended Data Content

Please refer to chapter 7.3 for detailed information.

3.4.4 Diagnostic Mode

In normal operation mode, the sensor transmits sensor output data in data range 1. A special "diagnostic mode" is foreseen for testing and failure analysis. In the diagnostic mode, the sensor may send other than the specified sensor output data in data range 1.

The condition for entering the diagnostic mode is the recognition of a valid "XLong" data frame during initialization phase II. The sensor indicates the diagnostic mode by sending the "Sensor in diagnostic mode" identifier during initialization phase III, see chapter 3.3.1.

4 ECU to Sensor Communication

Whereas the sensor to ECU communication is realized by current signals, voltage modulation on the supply lines is used to communicate with the sensors. The PSI5 “sync signal” is used for the sensor synchronization in all synchronous operation modes and also as physical layer for bidirectional communication.

4.1 Physical Layer

A logical “1” is represented by the presence of a sync signal, a logical “0” by the absence of a sync signal at the expected time window of the sync signal period. The voltage for a logical “0” must remain below the 0.5V limit specified as the sync signal t_0 start condition.

4.2 Data Link Layer

4.2.1 Bit Coding

The bit period is the cycle time as specified for the operation mode, e.g. 500 μ s in the PSI5-P10P-500/3L mode. The lower limit is depending on the filter characteristics of the hardware circuitry used for the sync signal detection (subsequent sync signals might vary the internal $V_{ss, base}$ reference).

4.2.2 Data Framing

The data frames of the sensor to ECU communication are composed by three start bits, a data field containing the sensor address, function code and data, a three bit CRC and additional three sync periods for the sensor response. Three different data frames with different data field lengths are available, “short”, “long” and “xlong”.

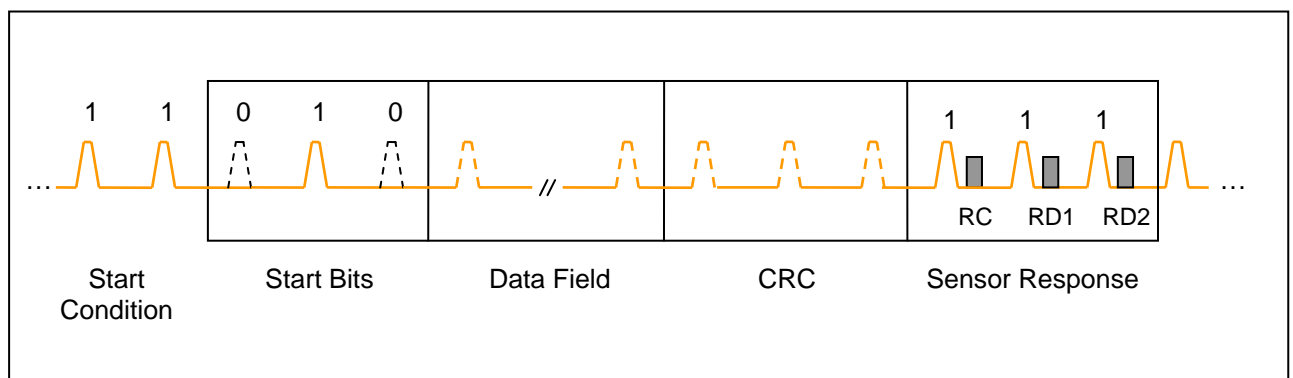

Figure 19 Data frame ECU to sensor communication

The start condition for an ECU to sensor communication consists of either at least five consecutive logical zeros or at least 31 consecutive logical ones. The sensor responds with the standard sensor to ECU current communication in its corresponding time slots.

As a consecutive train of “zeros” would lead to a loss of the common timebase, “sync bits” (logical “1”) are introduced at each fourth bit position.

4.2.3 Data Frames

Frame 1 „Short“																															
Start				SAdr				FC			CRC			Resp																	
0	1	0	S	A0	A1	A2	S	F0	F1	F2	S	C2	C1	C0	RC	RD1															
N° Bits: 15+2 (8.5ms @ 500µs)																															
Frame 2 „Long“ (4-Bit Data Nibbles)																															
Start				SAdr				FC			RAdr				Data				CRC			Resp									
0	1	0	S	A0	A1	A2	S	F0	F1	F2	S	X0	X1	X2	S	X3	X4	X5	S	D0	D1	D2	S	D3	C2	C1	S	C0	RC	RD1	RD2
N° Bits: 29+3 (16ms @ 500µs); Address / Data Range: 64 x 4 Bit																															
Frame 2 „Long“ (8-Bit Data Word)																															
Start				SAdr				FC			RAdr		Data						CRC			Resp									
0	1	0	S	A0	A1	A2	S	F0	F1	F2	S	X0	X1	D0	S	D1	D2	D3	S	D4	D5	D6	S	D7	C2	C1	S	C0	RC	RD1	RD2
N° Bits: 29+3 (16ms @ 500µs); Address / Data Range: 4 x 8 Bit																															
Frame 3 „XLong“																															
Start				SAdr				FC			RAdr				Data				CRC			Resp									
0	1	0	S	A0	A1	A2	S	F0	F1	F2	S	X0-X7 + Sync Bits				D0-D7 + Sync Bits				C2	C1	S	C0	RC	RD1	RD2					
N° Bits: 37+3 (20ms @ 500µs); Address / Data Range: 256 x 8 Bit																															

S Synchronisation Bit

The data frame length is defined by the content of the Sensor Address (SAdr) and the Function Code (FC) content. An separate identification field for the specification of the data frame type is not implemented due to timing considerations.

4.2.4 Sensor Addresses

Mnemonic	SAdr			Signification
	A2	A1	A0	
S0	0	0	0	Address of an unprogrammed sensor (Daisy Chain)
S1	0	0	1	Sensor 1 (Slot #1)
S2	0	1	0	Sensor 2 (Slot #2)
S3	0	1	1	Sensor 3 (Slot #3)
S4	1	0	0	Sensor 4 (Slot #4)
S5	1	0	1	Sensor 5 (Slot #5)
S6	1	1	0	Sensor 6 (Slot #6)
BCast	1	1	1	Broadcast address for all sensors

4.2.5 Function Codes

Mnemonic	SAdr			FC			Signification	Response	
	A2	A1	A0	F2	F1	F0		o.K.	Error
Set Sensor Address & Run Command (Short Data Frame) Condition: SAdr = "000" or SAdr = "111"									
SetAdr	0	0	0	Address to be programmed			Set Sensor Address & Close Bus Switch (The "FC" field contains the sensor address)	RC: "o.K." RD1: "Address"	RC: "Error" RD1: "ErrN°"
				A2	A1	A0			
Run	1	1	1	0	0	0	Sensors to enter "Run Mode" (Broadcast Message to all sensors)	RC: "o.K." RD1: "0000"	RC: "Error" RD1: "ErrN°"
Execute device specific function (Short Data Frame) Condition: SAdr = "001" to "110" and F2="1"									
Exec 1	Sensor Address 001 .. 110			1	0	0	Execute Specific Function #1	RC: "o.K." RD1: Specific	RC: "Error" RD1: "ErrN°"
Exec 2				1	0	1	Execute Specific Function #2		
Exec 3				1	1	0	Execute Specific Function #3		
Exec 4				1	1	1	Execute Specific Function #4		
Read / Write Command (Long Data Frame) Condition: F2="0" and F1="1"									
RD_L	Sensor Address 001 .. 110			0	1	0	Read nibble or byte from sensor (*)	RC: "o.K." RD1: Data_Lo RD2: Data_Hi (**)	RC: "Error" RD1: "ErrN°" RD2: "0000"
WR_L				0	1	1	Write nibble or byte to sensor (*)		
Read / Write Command (XLong Data Frame) Condition: F2="0" and F1="0"									
RD_X	Sensor Address			0	0	0	Read data byte from sensor	RC: "o.K." RD1,RD2: Data	RC: "Error" RD1: "ErrN°"
WR_X				0	0	1	Write data byte to sensor		

(*) Nibble (4 Bit) or Byte (8 Bit) instruction depending on device internal memory organization

(**) In case of Nibble (4 Bit) transmission Data_Hi has to be zero.

4.2.6 Returned Error Codes

ErrN°	Mnemonic	Signification
0000	General	General Error (*)
0001	Framing	Framing Error
0010	CRC	CRC Checksum Error
0011	Address	Sensor Address not supported
0100	FC	Function code not supported
0101	Data Range	Data range (register address) not supported
0110	Write Protect	Destination address write protected
0111		Reserved
1xxx		Application specific

(*) Unspecific, may replace all other error codes

5 Parameter Specification

All voltage and current values are measured at the sensor's connector pins unless otherwise noted. Values in brackets denote redundant parameters that can be calculated by other specified values and are for illustration purposes only. All parameters are valid under all operating conditions including temperature range and life time.

5.1 General Parameters

5.1.1 Absolute Maximum Ratings

N°	Parameter	Symbol/Remark	Min	Typ	Max	Unit
1	Supply voltage	$V_{SS \max}$, $V_{CE \max}$			16.5	V
2	Reverse polarity protection (standard) **	$t < 80\text{ms}$	-105			mA
3	Reverse polarity protection (extended) **	$t < 50\text{ms}$	-130			mA

** ECU to switch off the supply voltage after max. 80ms and 50ms respectively.

5.1.2 System Parameters

N°	Parameter	Symbol/Remark	Min	Typ	Max	Unit
1*	Supply Voltage	V_{SS}	5.0		11.0	V
2*	Supply Voltage (Standard Voltage)	V_{CE}	5.5		11.0	V
3*	Supply Voltage (Increased Voltage)	V_{CE}	6.5		11.0	V
4*	Interface Quiescent Current (Standard Current)	I_{LOW}	4.0		19.0	mA
5*	Interface Quiescent Current (Extended Current)	I_{LOW}	4.0		35.0	mA
6*	Drift of quiescent current		-4.0		4.0	mA
7	Quiescent current, drift rate				1.0	mA/sec
8	ECU current limitation (Standard Current)	I_{LIMIT}	50.0		105	mA
9*		$I_{LIMIT, dynamic}$	65.0			mA
10	ECU current limitation (Extended Current)	I_{LIMIT}	65.0		130	mA
11*		$I_{LIMIT, dynamic}$	80.0			mA
12*	Daisy Chain Sensor Quiescent Current	$I_{LOW, sensor}$	4.0		12.0	mA

- 1*) To be guaranteed by the ECU at the pins of the sensors under all conditions including dynamic load conditions in Asynchronous Mode and Parallel Bus Mode.
- 2*) To be guaranteed by the ECU at the output pins of the ECU under all conditions including dynamic load conditions in Universal Bus Mode and Daisy Chain Bus Mode.
- 3*) Optional increased supply voltage to overcome additional voltage drops in Universal Bus and Daisy Chain Bus applications.
- 4,5*) Parameters denote the sum over all sensors.
- 5*) Extended current range for higher current consumption e.g in bus or sensor cluster configurations.
- 6*) I_{LOW} is the (initial) quiescent current of the bus. Over lifetime and temperature, the quiescent current may vary by +/- 4.0 mA but must not exceed the limits for I_{LOW} . Means for an adaptive current threshold may be required in the receiver in order to cope with varying quiescent currents, especially when connected in bus systems.
- 8-11*) A maximum slope rate of 55mA/μs has to be provided by the ECU.
- 9,11*) Dynamic load condition: The ECU must have the capability to provide the current $I_{LIMIT, dynamic}$ for at least 10μs. For Daisy Chain Bus Mode this current has to be provided for at least 10ms when a sensor is powered on.
- 12*) In Daisy Chain Bus Mode the quiescent current limitations apply for a single sensor.

5.2 Sensor Power-on Characteristics

To ensure a proper startup of the system, a maximum startup time is specified. During this time, the ECU must provide a minimum current to load capacitances in sensors and wires. After this time, the sensor must sink quiescent current within the specified tolerance band.

During power on the ECU may reduce the output voltage to limit the current. However, this situation must be avoided in case of the daisy chain bus. Therefore, in a Daisy Chain Bus the sensor architecture must ensure that the overall bus current stays below $I_{LIMIT, dynamic}$.

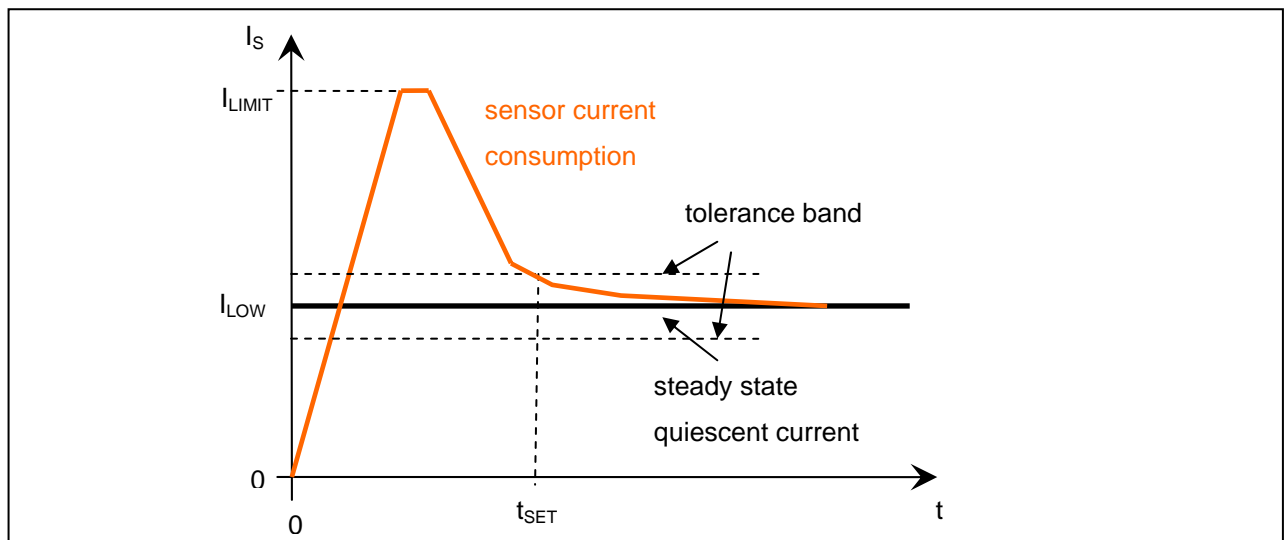

Figure 20 Current consumption during startup

N°	Parameter	Symbol/Remark	Min	Typ	Max	Unit
1*	Settling time for quiescent current I_{LOW}	t_{SET}			5.0	ms
2*	Settling time for quiescent current I_{LOW} (Daisy Chain Bus)	$t_{SET, Daisy Chain Bus}$			10.0	ms

- 1*) Final value settles to +/-2mA with respect to I_{LOW}
- 2*) Mandatory settling time for quiescent current in Daisy Chain Bus. The Bus does not sink a current over $I_{LIMIT, dynamic}$ at any time.

5.3 Undervoltage Reset and Microcut Rejection

The sensor must perform an internal reset if the supply voltage drops below a certain threshold for a specified time. By applying such a voltage drop, the ECU is able to initiate a safe reset of all attached sensors.

Microcuts might be caused by loose wires or connectors. Microcuts within the specified limits shall not lead to a malfunction or degraded performance of the sensor.

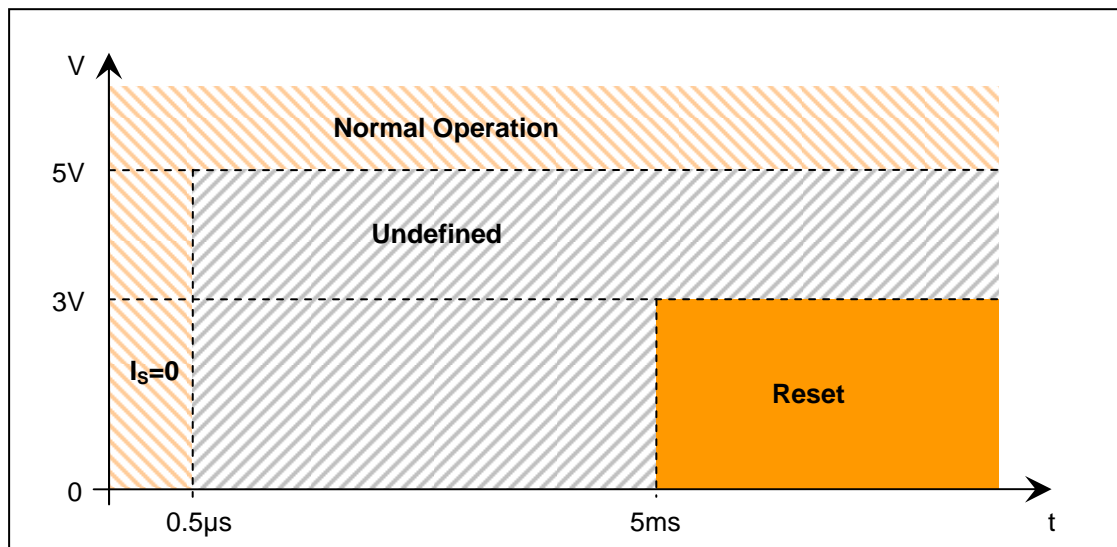

Figure 21 Undervoltage reset behaviour

N°	Parameter	Symbol/Remark	Min	Typ	Max	Unit
1	Undervoltage reset threshold	V_{TH}	3		5	V
2	Time below threshold for the sensor to initiate a reset	t_{TH}			5	ms
3	Microcut rejection time (no reset)	$I_S=0$	0.5			μs

The voltage V_{TH} is at the pins of the sensors. In case of microcuts ($I_S=0$) to a maximum duration of $0.5\mu s$ the sensor must not perform a reset. If the voltage at the pins of the sensor remains above 5V the sensor must not perform a reset. If the voltage at the pins of the sensor falls below 3V for more than 5ms the sensor has to perform a reset.

Different definitions may apply for Universal Bus and Daisy Chain Bus.

5.4 Data Transmission Parameters

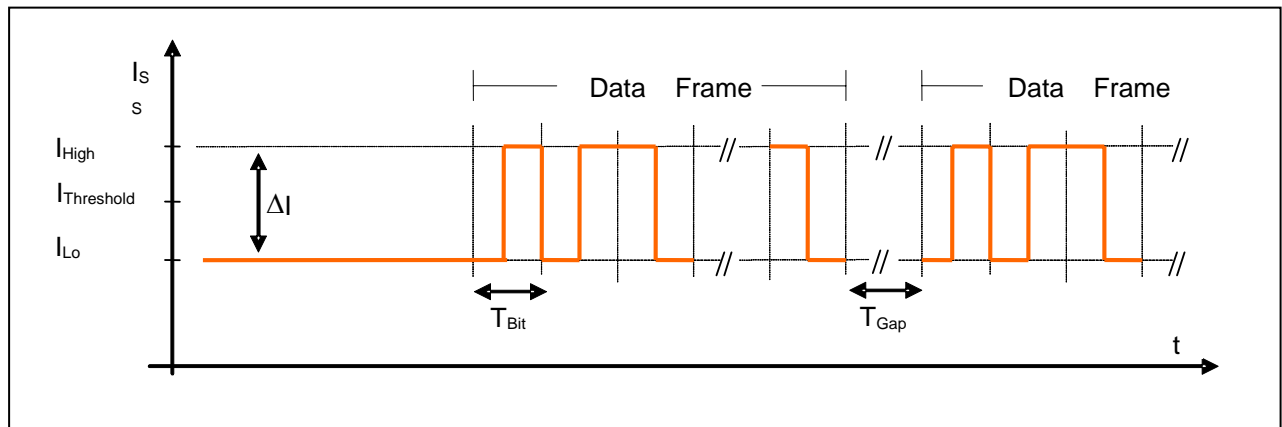

Figure 22 Data frame timing

N°	Parameter	Symbol/Remark	Min	Typ	Max	Unit
1	Bit time (125kbps mode)	T_{Bit}	7.6	8.0	8.4	μs
2	Bit time (189kbps mode)	T_{Bit}	5.0	5.3	5.6	μs
3*	Sensor clock deviation during data frame				0.1	%
4	Gap time (125 kbps mode)	$T_{Gap} > T_{Bit}$	8.4			μs
5	Gap time (189 kbps mode)	$T_{Gap} > T_{Bit}$	5.6			μs
6*	Sink current ΔI_s	$\Delta I_s = I_{S,High} - I_{S,Low}$	22.0	26.0	30.0	mA
7*	Fall/Rise Time Current Slope	20%..80% (of ΔI_s)	(0.33)		(1.0)	μs
8*	Mark/Space Ratio	$(t_{fall, 80} - t_{rise, 20}) / T_{Bit}$ $(t_{fall, 20} - t_{rise, 80}) / T_{Bit}$	47	50	53	%
9	Maximum clock drift rate				1	%/sec

All parameters related to the sensor.

- 3*) @ maximum temperature gradient and maximum frame length
- 6*) A lower min value was specified in older versions of this specification
- 7*) Small rise and fall times lead to increased radiated emission. Different definitions may apply for Universal Bus and Daisy Chain Bus. Parameters in brackets are given as a hint for the sensor development. (Sensors/Bus must meet the test conditions in chapter 6.6. Tighter tolerances might apply to the current sink in the transmitter.)
- 8*) Single sensor configuration, reference network "A" (see chapter 6.6)

5.5 Synchronization Signal

Purpose of the synchronization signal is to provide a time base for all devices connected to the interface. The synchronization signal is realized by a positive voltage modulation on the power supply lines.

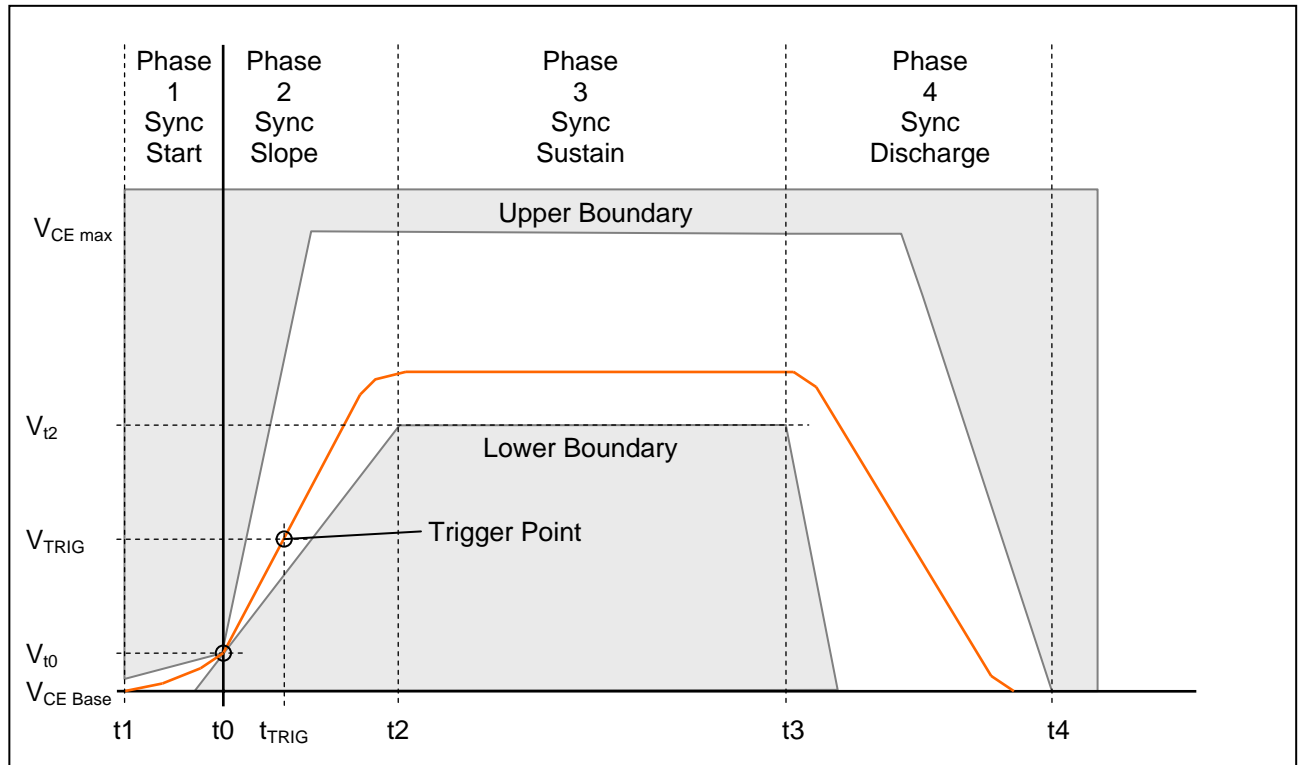

Figure 23 Synchronization Signal

The synchronization signal start time t_0 is defined as a crossing of the V_{I0} value. In the “Sync Start” phase before this point, a “rounding in” of the voltage starting from $V_{CE, Base}$ to V_{I0} is allowed for a maximum of t_1 . During the “Sync Slope” phase, the voltage rises within given slew rates to a value between the minimum sync signal voltage V_{I2} and the maximum interface voltage $V_{CE, max}$. After maintaining the voltage between this limits until a minimum of t_3 , the voltage decreases in the “Sync Discharge” phase until having reached the initial $V_{CE, base}$ value until latest t_4 .

N°	Parameter	Symbol	Remark	Min	Nom	Max	Unit
1	Base supply voltage (standard)	$V_{CE, BASE}$	Mean voltage value at ECU I/F	5.7		11.0	V
2*	Base supply voltage (increased)	$V_{CE, BASE}$	Mean voltage value at ECU I/F	6.7		11.0	V
3	Sync Slope Reference Voltage	V_{t0}	Referenced to $V_{CE, BASE}$		0.5		V
4	Sync signal sustain voltage	V_{t2}	Referenced to $V_{CE, BASE}$	3.5			V
5	Reference time	t_0	Reference time base		0		μs
6	Sync signal earliest start	t_1	Delta current less than 2mA		-3		μs
7	Sync signal sustain start	t_2	@ V_{t2}		7		μs
8*	Sync slope rising slew rate			0.43*		1.5	V/ μs
9	Sync slope falling slew rate			-1.5			V/ μs
10	Sync signal sustain time	t_3			16		μs
11*	Discharge time limit	t_4			35		μs
12	Start of first sensor data word	$t_{Slot 1 Start}$		44			μs

2*) Optional increased base supply voltage to overcome additional voltage drops in Universal Bus and Daisy Chain Bus applications.

8*) Lower limit is valid for V_{t0} to V_{t2}

11*) Remaining discharge current <2 mA, to be guaranteed by the ECU

In the sensors, the trigger is detected within the “trigger window” during the rising slope of the synchronization signal at the trigger point with the trigger voltage V_{TRIG} and the trigger time t_{TRIG} .

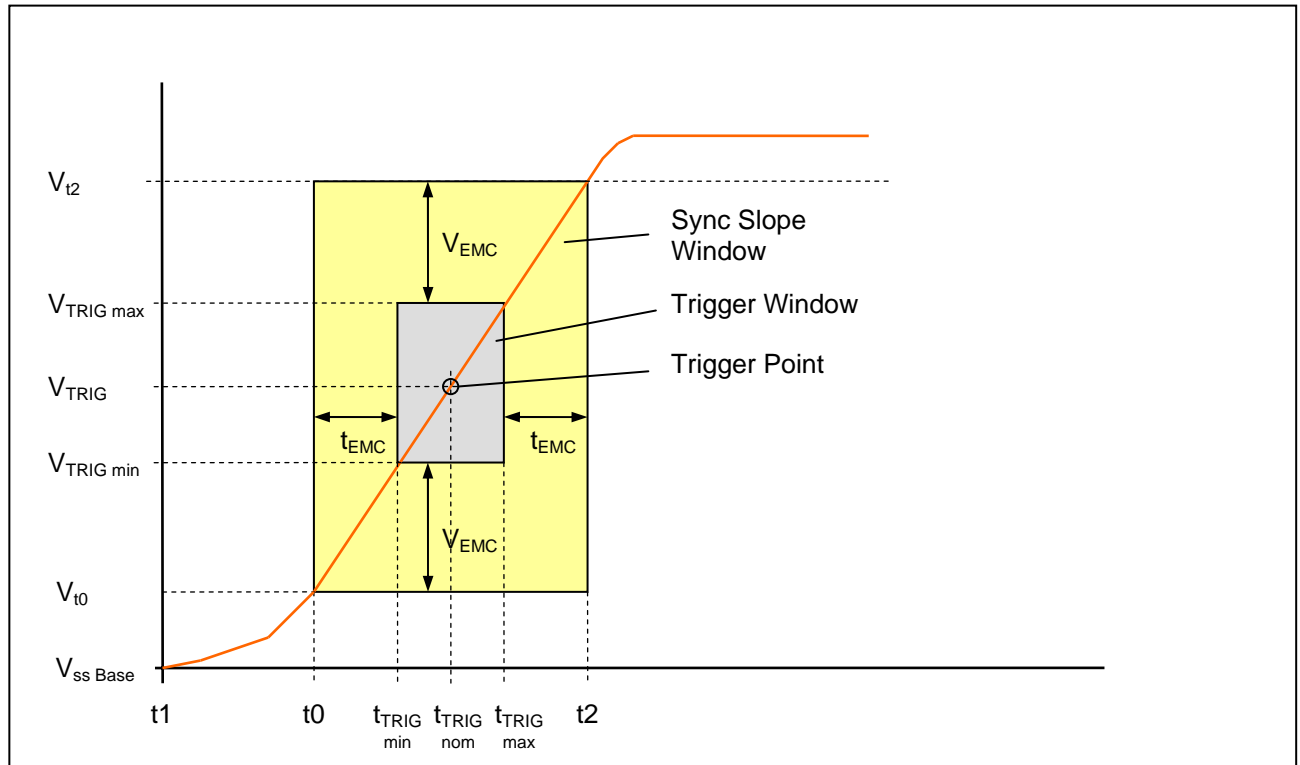

Figure 24 Trigger Point

In order to take into account voltage differences at different points of the interface lines, an additional safety margin for the trigger detection is defined by V_{EMC} and t_{EMC} .

N°	Parameter	Symbol	Remark	Min	Nom	Max	Unit
12	Margin for voltage variations of the signal on the interface line	V_{EMC}		-0.9		+0.9	V
13*	Sensor trigger threshold	V_{TRIG}	Sensor to detect trigger	1.4	2.0	2.6	V
14*	Nominal trigger detection time	t_{TRIG}	@ V_{TRIG} , @ Sensor Pins	(2.1)	(3.5)	(4.9)	μs
15	Margin for timing variations of the signal on the interface line	t_{EMC}	Relative to nominal trigger window time	-2.1		+2.1	μs
16	Tolerance of internal trigger detection delay	$t_{tol\ detect}$				3	μs
17*	Trigger detection time	T_{TRIG}	$T_{TRIG} = t_{TRIG} + t_{tol\ detect} + t_{EMC}$ Reference for sensor timebase	0		10	μs

13*) Referenced to $V_{SS, BASE}$

14*) Referenced to a straight sync signal slope with nominal slew rate

17*) Additional fixed internal delays are possible but have to be considered for the data slot time calculation

5.6 Timing of Synchronous Operation Modes

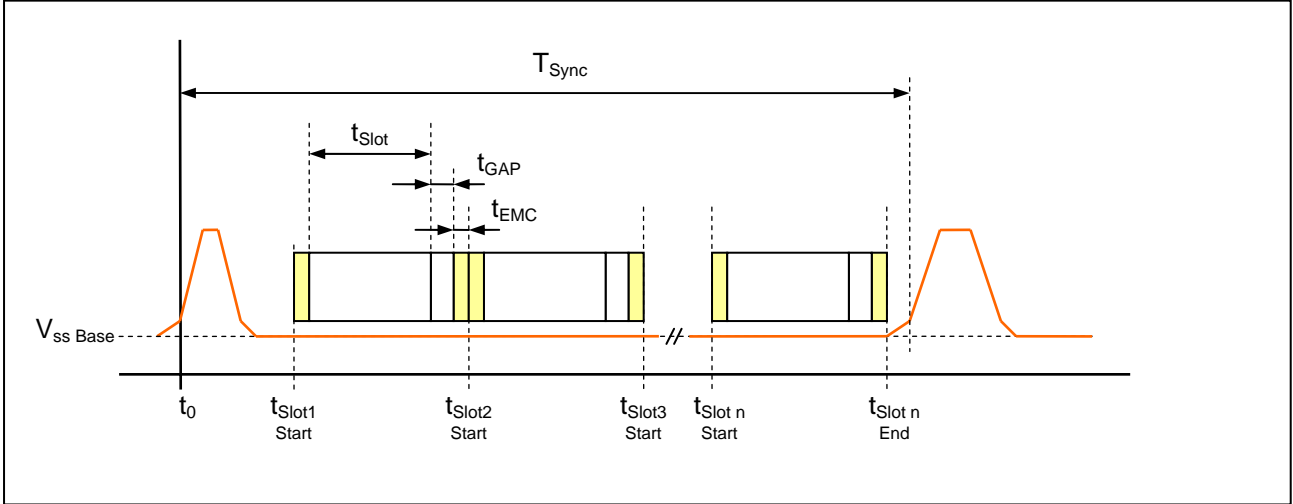

Figure 25 Timing of synchronous operation

Please refer to chapter 6.8 for the timing specification of recommended operation modes.

All rights including industrial property rights and all rights of disposal such as copying and passing to third parties reserved.

6 System Configuration & Test Conditions

6.1 System Modelling

6.1.1 Supply Line Model

PSI5 usually uses twisted pair lines which are modeled as shown in Figure 26. Parameter specification is done for the different system configurations. All indications are based on standard CAN cable with a maximum inductance of $0.72\mu\text{H}/\text{m}$.

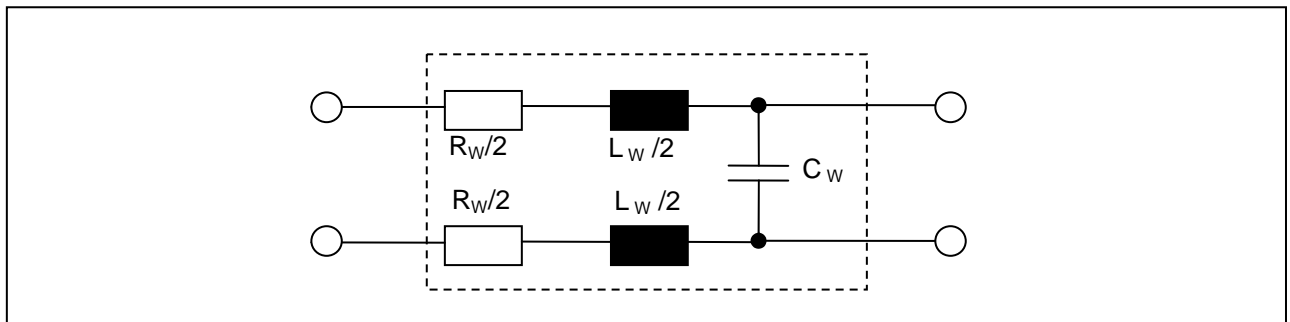

Figure 26 Supply line model for PSI5

6.2 Asynchronous Mode

Parameter Specification

N°	Parameter	Symbol/Remark	Min	Typ	Max	Unit
1*	Capacitive ECU bus load	C_E	6.0		47	nF
2*	Capacitive sensor bus load	C_S	6.0		47	nF
3	Internal ECU resistance	R_E	5		12.5	Ω
4	ECU Connector resistance	R_{CE}		(0.2)		Ω
5	Sensor Connector resistance	R_{CS}		(0.2)		Ω
6	Single wire resistance	$R_W/2$		(0.5)		Ω
7	Overall line resistance incl. wire	$2 * (R_{CE} + R_W/2 + R_{CS})$			2.5	Ω
8*	Wire inductance	$2 * (L_W / 2)$			8.7	μH
9	Wire capacitance	C_W			600.0	pF

*) Large cable lengths / inductances may require appropriate selection of sensor and ECU capacitance values and / or additional damping measures.

6.3 Parallel Bus Mode

Parameter Specification

N°	Parameter	Symbol/Remark	Min	Typ	Max	Unit
1*	Capacitive ECU bus load	C_E	15		35	nF
2*	Capacitive sensor bus load	C_S	9		24	nF
3*	Overall capacitive bus load	$C_{BUS}=C_E+\sum C_S$	(24)		(107)	nF
4	Internal ECU resistance	R_E	5		12.5	Ω
5	ECU Connector resistance	R_{CE}		(0.2)		Ω
6	Sensor Connector resistance	R_{CS}		(0.2)		Ω
7	Single wire resistance	$R_W/2$		(0.5)		Ω
8	Overall line resistance incl. wire (each wire)	$2 * (R_{CE} + R_W/2 + R_{CS})$			2.5	Ω
9	Wire inductance	$2 * (L_{Wn} / 2)$			8.7	μH
10	Wire capacitance	C_W			600.0	pF

All values specified for a 125kbps data rate and a maximum of three sensors.

1,2*) Damping is required in ECU and sensors to limit oscillations on the bus lines. Please refer to chapter 6.6 for the corresponding equivalent circuits

3*) Wire capacitance not included

6.4 Universal Bus Mode

Parameter Specification

N°	Parameter	Symbol/Remark	Min	Typ	Max	Unit
1*	Capacitive ECU bus load	C_E	15		35	nF
2*	Overall capacitive bus load	$C_{BUS}=C_E+\sum C_S$	24		107	nF
3	Internal ECU resistance	R_E	5		12.5	Ω
4	Bus inductance	$2 * (L_{Wn} / 2)$			8.7	μH
5	Bus capacitance	C_B	9		72	nF

All values specified for a 125kbps data rate.

1*) Damping is required in ECU to limit oscillations on the bus lines. Please refer to chapter 6.6 for the corresponding equivalent circuit.

2*) Wire capacitance not included

6.5 Daisy Chain Bus Mode

Parameter Specification

N°	Parameter	Symbol/Remark	Min	Typ	Max	Unit
1*	Capacitive ECU bus load	C_E	15		35	nF
2*	Overall capacitive bus load	$C_{BUS}=C_E+\sum C_S$	24		107	nF
3	Internal ECU resistance	R_E	5		12.5	Ω
4	Bus inductance	$2 * (L_{Wn} / 2)$			8.7	μH
5	Bus capacitance	C_B	9		72	nF

All values specified for a 125kbps data.

- 1*) Damping is required in ECU to limit oscillations on the bus lines. Please refer to chapter 6.6 for the corresponding equivalent circuit.
- 2*) Wire capacitance not included

6.6 Test Conditions & Reference Networks – Sensor Testing

6.6.1 Reference Networks for Asynchronous Mode and Parallel Bus Mode

All indications in this section are valid for asynchronous mode and parallel bus mode with up to three sensors and for a data transmission rate of 125kbps.

ECU and Wiring Reference Network for asynchronous mode and parallel bus mode

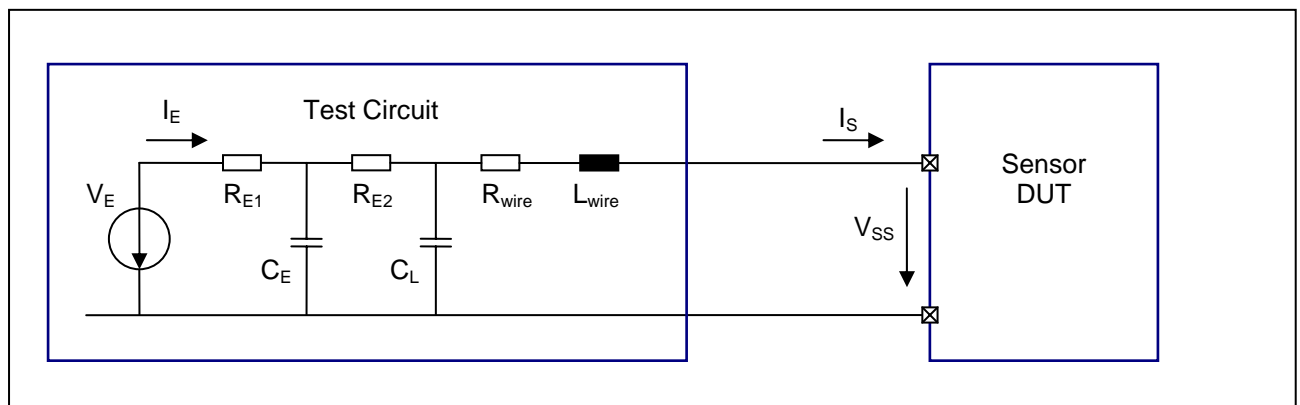

Figure 27 Reference test bench for sensor testing

N°	Parameter	Symbol/Remark	Min	Nom	Max	Unit
1*	Supply voltage	V_E			11	V
2*	ECU internal resistance	R_{E1}	2.5		10	Ω
		R_{E2}		2.5		Ω
3*	ECU internal capacitance	C_E	13		33	nF
4*	Bus load capacitance (ECU & other sensors)	C_L	2.2		50	nF
5*	Wire & connector resistance	R_{wire}	0.1		2.5	Ω
6*	Wire inductance	L_{wire}	0		8.7	μH

1*) Minimum supply voltage has to be adjusted to meet $V_{SS, min}$.

*) see corresponding test conditions in section 6.6.4.

Sensor damping behaviour for asynchronous mode and parallel bus mode

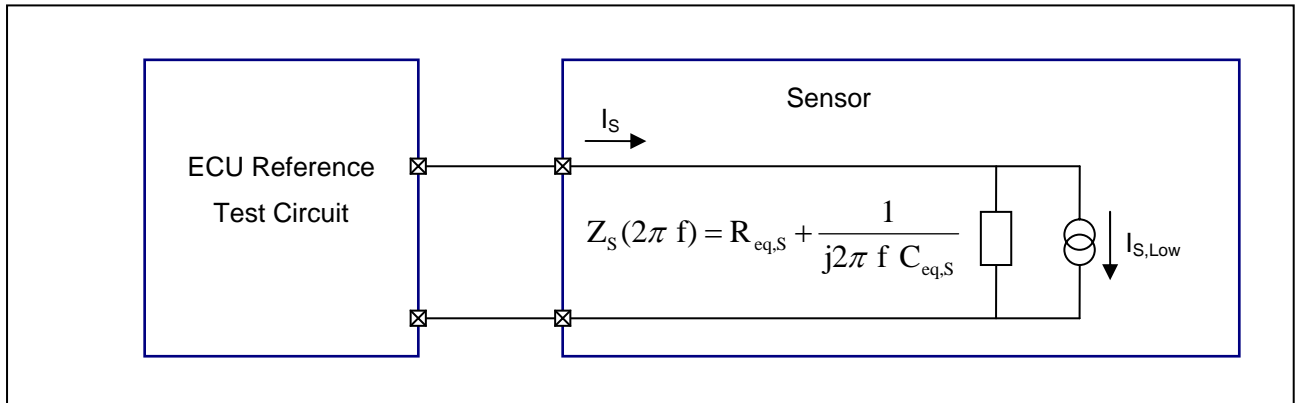

Figure 28 Reference circuit for sensor damping behaviour

N°	Parameter	Symbol/Remark	Min	Nom	Max	Unit
1	Sensor internal capacitance	$C_{eq,S}$	9		24	nF
2	Sensor internal resistance	$R_{eq,S}$	2.5			Ω
3	Frequency	f	10		2000	kHz

The sensor damping behaviour is described by a complex impedance Z_S containing of an equivalent resistance $R_{eq,S}$ and an equivalent capacitance $C_{eq,S}$ connected in serial. For the given frequency range Z_S has to stay in the limits defined in the table above.

6.6.2 Reference Networks for Universal Bus Mode and Daisy Chain Bus Mode

All indications in this section are valid for universal bus mode and daisy chain bus mode with up to three sensors and for a data transmission rate of 125kbps.

ECU reference network for universal bus mode and daisy chain bus mode

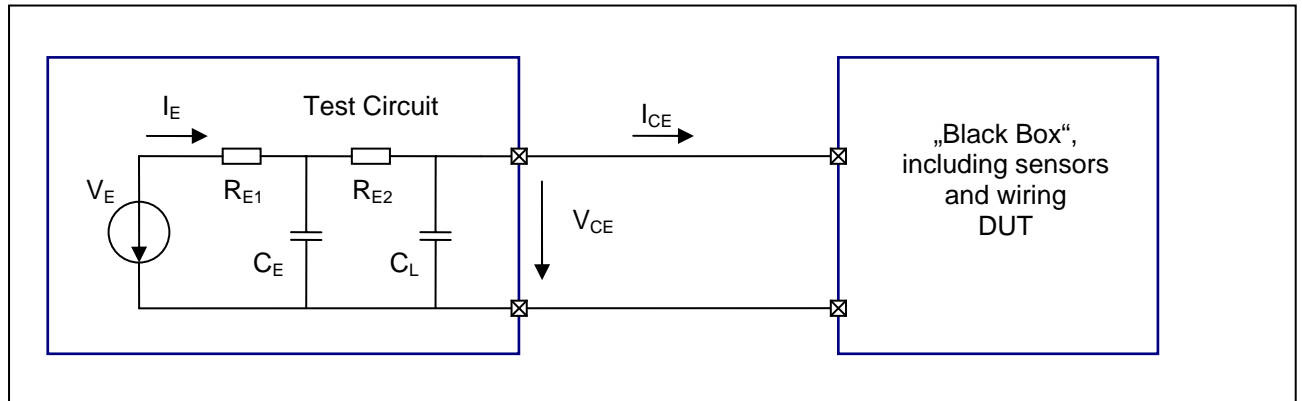

Figure 29 Reference test bench for bus testing

N°	Parameter	Symbol/Remark	Min	Nom	Max	Unit
1*	Supply voltage	V_E			11	V
2*	ECU internal resistance	R_{E1}	2.5		10	Ω
		R_{E2}		2.5		Ω
3*	ECU internal capacitance	C_E	13		33	nF
4	Bus load capacitance (ECU & other sensors)	C_L		2.2		nF

1*) Minimum supply voltage has to be adjusted to meet $V_{CE, min}$.

*) see corresponding test conditions in section 6.6.5.

6.6.3 Test Parameter Specification

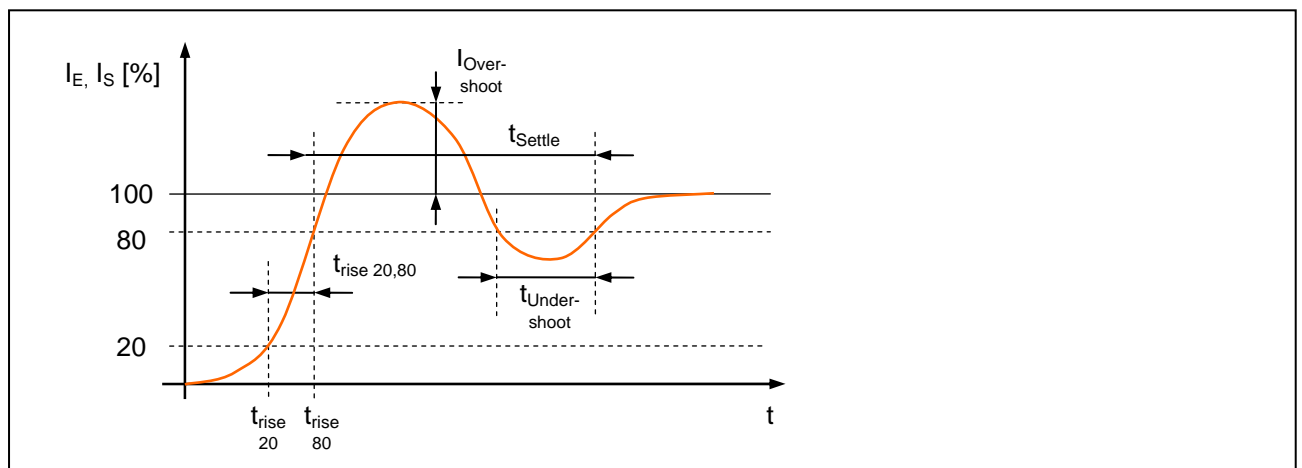

Figure 30 Test parameter sending current

6.6.4 Sensor Reference Tests for Asynchronous Mode and Parallel Bus Mode

The sensor has to fulfill the reference tests for every voltage V_E between a minimum voltage to meet $V_{SS,min}$ at the sensor pins and 11V.

N°	Parameter	Symbol/Remark	Min	Nom	Max	Unit
A	Worst case timing @ sensor					
	Test condition: $R_{E1} = 10\Omega$; $C_E = 33nF$; $C_L = 2.2nF$; $R_{wire} = 2.5\Omega$; $L_{wire} = 0\mu H$					
A1	Sending current rise/fall time (sensor)	$t_{rise\ 20, 80}$ & $t_{fall\ 80, 20}$ (I _S)			1	μs
B*	Worst case overshoot @ sensor					
	Test condition: $R_{E1} = 2.5\Omega$; C_E variable between 13nF and 33nF; $C_L = 2.2nF$; $R_{wire} = 0.1\Omega$; $L_{wire} = 8.7\mu H$					
B1	Sending current rise/fall time (sensor)		0.33			μs
B2	Sending current over- / undershoot @sensor	$I_{Overshoot, rise}$ & $I_{Undershoot, fall}$ (I _S)			50	%
B3	Time for under- / overshoot @ECU	$t_{Undershoot, rise}$ & $t_{Overshoot, fall}$ (I _E)			0.52	μs
B4	Settling time @ECU	t_{Settle} (I _E)			1.72	μs
B5	Voltage ripple @sensor	referenced to $V_{SS, base}$	-0.8		+0.8	V
C	Worst case timing @ ECU					
	Test condition: $R_{E1} = 10\Omega$; $C_E = 33nF$; $C_L = 50nF$; $R_{wire} = 2.5\Omega$; $L_{wire} = 0\mu H$					
C1	Sending current rise/fall time @ECU	$t_{rise\ 20, 80}$ & $t_{fall\ 80, 20}$ (I _E)			1.8	μs
D	Sensor internal damping					
	A sensor internal damping behaviour is required corresponding to the equivalent sensor reference network (see chapter 5.7.1).					
	A test condition for the sensor damping will be specified in a future version of this specification.					

See section 6.6.1 for ECU and wiring reference network.

B*) The sensor has to fulfill reference Test B for every value of the capacitance C_E between 13nF and 33nF.

6.6.5 Sensor Reference Tests for Universal Bus Mode and Daisy Chain Bus Mode

The sensor has to fulfill the reference tests for every voltage V_E between a minimum voltage to meet $V_{CE,min}$ at the output pins of the ECU and 11V.

N°	Parameter	Symbol/Remark	Min	Nom	Max	Unit
B	Worst case overshoot @ ECU output					
	Test condition: $R_{E1} = 2.5\Omega$; C_E variable					
B2	Sending current over- / undershoot @ ECU output pins	$I_{Overshoot, rise} \& I_{Undershoot, fall} (I_E)$			50	%
B3	Time for under- / overshoot @ ECU	$t_{Undershoot, rise} \& t_{Overshoot, fall} (I_E)$			0.52	μs
B4	Settling time @ ECU	$t_{Settle} (I_E)$			1.72	μs
C	Worst case timing @ ECU					
	Test condition: $R_{E1} = 10\Omega$; $C_E = 33nF$					
C1	Sending current rise/fall time @ECU	$t_{rise 20, 80} \& t_{fall 80, 20} (I_E)$			1.8	μs

See section 6.6.2 for ECU and wiring reference network.

B*) The sensor has to fulfill reference Test B for every value of the capacitance C_E between 13nF and 33nF.

6.7 Test Conditions & Reference Networks - Receiver / ECU Testing

Test conditions & reference networks for receiver / ECU testing will be specified in a future version of this specification.

Technical Specification	PSI5 Peripheral Sensor Interface	Page 42 / 46
		V1.3

6.8 Operation Modes

6.8.1 PSI5-P10P-500/3L Mode

N°	Parameter	Symbol	Remark	Value	Unit
1	Sync signal period	T_{Sync}		500	μs
2	Maximum tolerance of sync signal period			+/-1	%
3	Slot 1 start time	$t_{Slot1, Start}$	Related to t_0	44	μs
4	Slot 2 start time	$t_{Slot2, Start}$	Related to t_0	181.3	μs
5	Slot 3 start time	$t_{Slot3, Start}$	Related to t_0	328.9	μs
6	Slot 3 end time	$t_{Slot3, End}$	Related to t_0	492	μs

The timings also apply for universal bus mode and daisy chain bus mode.

6.8.2 PSI5-P10P-500/4H Mode

N°	Parameter	Symbol	Remark	Value	Unit
1	Sync signal period	T_{Sync}		500	μs
2	Maximum tolerance of sync signal period			+/-1	%
3	Slot 1 start time	$t_{Slot1, Start}$	Related to t_0	44	μs
4	Slot 2 start time	$t_{Slot2, Start}$	Related to t_0	139.5	μs
5	Slot 3 start time	$t_{Slot3, Start}$	Related to t_0	245.5	μs
6	Slot 4 start time	$t_{Slot4, Start}$	Related to t_0	362.5	μs
7	Slot 4 end time	$t_{Slot4, End}$	Related to t_0	492	μs

The timings also apply for universal bus mode and daisy chain bus mode.

7 Appendix A

7.1 Interoperability Requirements

PSI5 defines all basic characteristics of an electrical sensor interface including the physical layer, data link layer and - to a certain extent - the application layer. Interoperability between ECU and sensors (asynchronous mode and parallel bus mode) or bus (universal bus mode and daisy chain mode) requires the definition of the following additional, system specific parameters:

- Sensor configurations & operation modes (single sensor, bus configuration or sensor cluster)
- Current driving capabilities vs. current load of the sensors (standard or extended)
- Initialization data content i.e. also including determination of the repetition count (k)

Other sensor parameters such as mechanical and dimensional characteristics, signal evaluation path and functional characteristics or reliability and environmental test conditions are beyond the scope of the PSI5 specification and have to be specified in separate documents to assure cross compatibility.

7.2 Recommended Configurations

The following data word lengths are specified:

Data word length	Purpose
8	low resolution sensors
10	medium resolution sensors
16	high resolution sensors
20	2 channel multiplex datawords
24	2 channel multiplex datawords

Recommended PSI5 Operation Modes

Asynchronous Operation		
Mode	Sensor Data	Description
A8P	250/1L	min. 1 value each 250µs (incl. tolerances)
A10P	250/1L	min. 1 value each 250µs (incl. tolerances)
A16CRC	500/1L	min. 1 value each 500µs (incl. tolerances)
Synchronous Operation		
Bus Mode	Sensor Data	Description
P10P	250/1L	Single sensor 4kHz data transmission
P10P	500/2L	Two message slot parallel bus / 500µs data rate
P10P	500/3L	Three message slot parallel bus / 500µs data rate
P10P	500/4H	Four message slot parallel bus / 500µs data rate
P16CRC	500/2L	Two high resolution sensors parallel bus / 500µs data rate

7.3 Status Data Content

The data transmitted in initialization phase II is specified here (see chapter 3.4.3). The data message repetition count k has to be between 1 and 16. Typically k has a value of 4. The following table is related to the sensor definition in Figure 1.

Field	Name	Parameter definition	Value
F1-F5: Mandatory information for all sensors			
F1 (D1)	Protocol Description (D1) Revision of the interface specification: Currently fixed to "0100"	PSI5 Spec V1.x	0100
F2 (D2, D3)	Number of data blocks (D2, D3) Number of data nibbles transmitted during initialization.	Examples : F1-F5 = 9 Nibbles F1-F9 = 32 Nibbles	Examples : 0000 1001 0010 0000
F3 (D4, D5)	Sensor Manufacturer Code	Autoliv	0100 0000
		Bosch	0001 0000
		Continental	1000 0000
		SiemensVDO	0010 0000
		Sensor manufacturer not specified	0000 0000
		TRW	0101 0100
		Freescale	0100 0110
		other sensor manufacturers	tbd
F4 (D6, D7)	Sensor Type Definition of the sensor type (acceleration, pressure, temperature, torque, force, angle, etc.)	Acceleration Sensor (High g)	XXXX 0001
		Acceleration Sensor (Low g)	XXXX 0010
		Pressure Sensor	XXXX 1000
		other sensors	tbd
F5 (D8, D9)	Sensor Parameter Definition of sensor specific parameters e.g . measurement range.	Information depending on the corresponding sensor type	Sensor specific definition
F6-F9: Recommended information for automotive applications			
F6 (D10,D11)	Sensor Code (Sensor manufacturer) Definition of sensor specific parameters or additional information.	To be specified by the sensor manufacturer.	Sensor specific definition
F7 (D12-D14)	Sensor Code (Sensor application)	Usage e.g. for product revision information.	Sensor specific definition
F8 (D15-D18)	Sensor Production Date Production date of the sensor.	Binary coded julian date: Year: 00-99 (7 bit value) Month: 01-12 (4 bit value) Day: 01-31 (5 bit value)	Example: 2006: 0000110 March: 0011 30: 11110
F9 (D19-D32)	Sensor Trace information E.g. production lot / line / serial number	To be specified by the sensor manufacturer	Sensor specific definition

8 Document History & Modifications

Rev.N°	Chapter	Description / Changes	Date
1.0	all	First Edition	15.07.2005
1.1	div.	see Version 1.1	30.06.2006
1.2	1.2	Optional 189kbps data transmission speed added	12.06.2007
	2.3	Synchronous operation: new denomination for operation modes	
	2.3.2	Serial topology: changed form voltage shift method to low-side "daisy chain" switching with bidirectional addressing sequence	
	3.3.1	Data Range: Updated Status & Error Messages	
	3.3.2	Scaling of data range: definition for initialization data added	
	3.4.1	Description of Initialization phase extended	
	3.4.2	Initialization data content summarized in chapter 3.4.3; Mandatory header information includes F5 - sensor parameter.	
	4	Structure of parameter specification reorganized; General parameters (4.1) : - Quiescent current 4 .. 19mA, extended current max. 35mA - Current limitation added Data transmission parameters (4.4) : - correction of start bit values in the data frame timing figure - bit time for 189kbps mode added - communication current tolerance narrowed - fall / rise time communication current changed (see chapter 5) - clock drift rate specified Synchronization signal (4.5): - detailed specification of only one, unified sync signal Timing of synchronous operation modes (4.6): - specification of time slots	
5	System configurations (new chapter): - denomination of PSI5 operating modes specified (5.1) - recommended operating modes (5.2) - detailed system configuration: asynchronous operation (5.4) - detailed system configuration: parallel bus modes (5.5.1, 5.5.2) - detailed system configuration: serial bus mode (5.6) - reference networks & test conditions (5.7) - operation modes PSI5-P10P (5.8)		
1.3	div.	Siemens VDO replaced by Continental	06.06.2008
	2.2	Shifted from Chapter 5. Denomination of operation modes changed: - Asynchron - Parallel Bus (Parallel Configuration) - Universal Bus (Pass-Through Configuration)	

Technical Specification	PSI5 Peripheral Sensor Interface	Page 46 / 46
		V1.3

		- Daisy Chain Bus (Serial Configuration)	
2.3;2.4		Simplified diagrams of sensor configurations shifted from Chapter 5	
3		Chapter renamed: Sensor to ECU Communication	
3.4.4		Diagnostic Mode added.	
4		Chapter added: ECU to Sensor Communication	
5.1.1		Reverse polarity protection: - 100ms replaced by 80ms and 50ms respectively - min value of 105mA for standard mode	
5.1.2		- Supply voltage for Universal Bus and Daisy Chain Bus added - Daisy Chain Sensor Quiescent Current added	
5.2		Optional settling time for Daisy Chain Bus added	
5.3		Figure replaced for clarity	
6.3		Min value for capacitive sensor bus load changed to 6nF	
6.4		Parameter Specification for Universal Bus added	
6.5		Parameter Specification for Daisy Chain Bus added	
6.6.1		- Definition of max value for supply voltage instead of nominal value - Definition of min and max value for ECU internal capacitance instead of nominal value - Sensor damping behaviour redefined	
6.6.2		Reference network for Universal Bus Mode and Daisy Chain Bus Mode added	
7.2		Recommended Configurations shifted from Chapter 5.2	

All rights including industrial property rights and all rights of disposal such as copying and passing to third parties reserved.